



CONTENT

SUBJECT/SUBJECT CODE - 4030511/CONTROL OF ELECTRICAL MACHINES

- 1. NOTES OF LESSON INDEX PAGE**
- 2. NOTES OF LESSON (VIDEO LINK,PPTLINK ATTACHED IN THE INDEX PAGE)**

**PREPARED BY:
1.Mr.P.THIRUMOORTHY**

REVOLUTION THROUGH TECHNOLOGY

764 - SRIPC



NOTES OF LESSON –INDEX PAGE

YEAR	3rd YEAR	SEMESTER	V SEMESTER
SUBJECT/SUBJECT CODE	4030511/ CONTROL OF ELECTRICAL MACHINES	SCHEME	N-SCHEME

UNIT-I-CONTROL CIRCUIT COMPONENTS

S.NO.	TOPIC	REFER TEXT BOOK NAME	VIDEO PRESENTATION	PPT	ANY OTHER	
1	Switches – Push button	Control of Electrical Machines S.K.Battacharya	-	PPT	-	
2	Selector switch		-	PPT	-	
3	Drum switch		-	PPT	-	
4	Limit switch		-	PPT	-	
5	Pressure switch		-	PPT	-	
6	Temperature (Thermostat) switch		-	-	-	Notes
7	Float switch		-	-	-	Notes
8	zero speed switch		-	-	-	Notes
9	proximity switches		-	-	-	Notes
10	Relays – Voltage relay		-	-	PPT	-
11	DC series current relay		-	-	PPT	-
12	Frequency response relay		-	-	PPT	-
13	latching relay		-	-	PPT	-
14	Phase failure relay (single phasing preventer).		-	https://youtu.be/YH_KMQGIDHY	-	-
15	Over current relay		-	-	-	Notes
16	Bimetallic thermal over load relay		-	https://youtu.be/rdJ0TR3qy2M	-	ohp
17	Magnetic dash pot oil filled relay		-	-	-	Notes
18	Timer – Thermal Pneumatic		-	-	-	Notes
19	Electronic timer		-	https://youtu.be/sL1ZEcy9gM	-	-
20	Solenoid Valve		-	-	-	Notes
21	Solenoid type contactor (Air break contactor)		-	https://youtu.be/-MLGr1_Fw0c	-	-
22	Solid state relay		-	-	-	Notes
23	Simple ON-OFF motor control circuit		-	-	PPT	-
24	Remote control operation and interlocking of drives		-	-	PPT	-

UNIT-II-MOTOR CONTROL CIRCUITS

S.NO.	TOPIC	REFER TEXT BOOK NAME	VIDEO PRESENTATION	PPT	ANY OTHER
1	Series Relay	Industrial Motor Control Stephen Herman	https://youtu.be/2n0vUa0cZ OI	-	-
2	Counter EMF Starters		https://youtu.be/dzQ_Lw6GS Qs	-	-
3	Field Failure Protection		https://youtu.be/Pa2Cy77KG 0c	PPT	-
4	Jogging Control		https://youtu.be/n2FYuf01R wg	-	-
5	Dynamic Braking		https://youtu.be/4v7qMYUIH HA	-	-
6	DOL Starter		https://youtu.be/6BcpqDEW8 24	-	-
7	Three Step Rotor Resistance Starter for Wound Induction Motor		-	PPT	-
8	Secondary Frequency Acceleration Starter.		-	PPT	-
9	Automatic Auto Transformer Starter (Open Circuit Transition)		-	-	Notes
10	Automatic Auto Transformer Starter (Closed-Circuit Transition)		-	-	Notes
11	Star/Delta Starter (Semi-Automatic)		-	-	Notes
12	Star/Delta Starter (Automatic)		-	-	Notes
13	Starter for Two Speed Two Winding Motor		-	PPT	-
14	Reversing the Direction of Rotation of Induction Motor		-	-	Notes
15	Dynamic Braking		-	-	Notes

UNIT-III-INDUSTRIAL CONTROL CIRCUITS

S.NO.	TOPIC	REFER TEXT BOOK NAME	VIDEO PRESENTATION	PPT	ANY OTHER
1.	Planner Machine Control	Control of Electrical Machines S.K.Battacharya	-	-	Notes
2.	Skip Hoist Control		https://youtu.be/S5L8XVSF4HM	-	-
3.	Automatic Control of a Water Pump		https://youtu.be/cQ9LD808dMo	-	-
4.	Control of Electric Oven		-	-	Notes
5.	Control of Air Compressor		-	-	Notes
6.	Control of Over Head Crane		-	PPT	-
7.	Control of Battery-Operated Truck		https://youtu.be/Y6WM5xByJtg	-	-
8.	Control of Conveyor System		-	-	Notes
9.	Control of Elevator		-	PPT	-
10.	Trouble Spots in Control Circuits – General Procedure for Trouble Shooting		-	PPT	-

UNIT-IV-PROGRAMMABLE LOGIC CONTROLLER

S.NO.	TOPIC	REFER TEXT BOOK NAME	VIDEO PRESENTATION	PPT	ANY OTHER
1	Automation – Types of Automation (Manufacturing and Non- Manufacturing) Advantages of Automation	Exposing Programmable Logic Controllers with Application Pradeep Kumar, Srivastava	-	PPT	-
2	PLC Introduction – Block Diagram of PLC–Principle of Operation		-	PPT	-
3	Modes of Operation		-	-	Notes
4	PLC Scan		-	-	Notes
5	Memory Organization		-	-	Notes
6	Input Module (Schematic and Wiring Diagram)		-	-	Notes
7	Output Module (Schematic and Wiring Diagram).		-	-	Notes
8	Types of Programming Devices		-	-	Notes
9	Comparison between Hardwire Control System and PLC System		-	PPT	-
10	PLC Types (Fixed and Modular)		-	PPT	-
11	Input Types & Output Types		-	-	Notes
12	Criteria for Selection of Suitable PLC		-	PPT	-
13	List of Various PLCs available		-	PPT	-

UNIT-V- PLC PROGRAMMING AND SCADA

S.NO.	TOPIC	REFER TEXT BOOK NAME	VIDEO PRESENTATION	PPT	ANY OTHER
1.	Different Programming Languages – Ladder Diagram – Relay Type Instruction – Timer Instruction – ON Delay and OFF Delay Timer – Retentive Timer Instruction – Cascading Timers – Counter Instruction UP Counter – Down Counter – UP/DOWN Counter.	Practical SCADA for Industry David Bailey, Edwin Wright	-	PPT	-
2.	Ladder Logic Diagram for DOL Starter		-	-	Notes
3.	Automatic STAR-DELTA Starter		-	-	Notes
4.	Rotor Resistance Starter		-	-	Notes
5.	EB to Generator Change over System		-	PPT	-
6.	Supervisory Control Data Acquisition System (SCADA) – Block Diagram of SCADA, Features and Functions of SCADA – Introduction to DCS.		-	-	OHP

Department of Electrical & Electronics Engineering

Name of the staff : P.Thirumoorthy
Course with code : 4030511-Control of Electrical Machines
Programme : Diploma in Electrical & Electronics Engineering
Semester / Branch : V / Electrical & Electronics Engineering

Unit –I CONTROL CIRCUIT COMPONENTS

Switches – Push Button, Selector, Drum, Limit, Pressure, Temperature (Thermostat), Float, Zero Speed and Proximity Switches. Relays – Voltage Relay, DC Series Current Relay, Frequency Response Relay, Latching Relay and Phase Failure Relay (Single Phasing Preventer). Over Current Relay – Bimetallic Thermal Over Load Relay and Magnetic Dash Pot Oil Filled Relay.

Timer – Thermal Pneumatic and Electronic Timer. Solenoid Valve, Solenoid Type Contactor (Air Break Contactor), Solid State Relay, Simple ON-OFF Motor Control Circuit, Remote Control Operation and Interlocking of Drives.

Unit – II MOTOR CONTROL CIRCUITS

CHAPTER: 2.1: DC MOTOR CONTROL CIRCUITS

Series Relay and Counter EMF Starters – Field Failure Protection – Jogging Control, Dynamic Braking

CHAPTER: 2.2: AC MOTOR CONTROL CIRCUITS

DOL Starter – Automatic Auto Transformer Starter (Open Circuit and Closed-Circuit Transition) – Star/Delta Starter (Semi-Automatic and Automatic) – Starter for Two Speed Two Winding Motor – Reversing the Direction of Rotation of Induction Motor – Dynamic Braking – Three Step Rotor Resistance Starter for Wound Induction Motor – Secondary Frequency Acceleration Starter.

Unit –III INDUSTRIAL CONTROL CIRCUITS

Planner Machine Control – Skip Hoist Control – Automatic Control of a Water Pump – Control of Electric Oven – Control of Air Compressor – Control of Over Head Crane - Control of Battery-Operated Truck – Control of Conveyor System – Control of Elevator - Trouble Spots in Control Circuits – General Procedure for Trouble Shooting.

Unit –IV PROGRAMMABLE LOGIC CONTROLLER

Automation – Types of Automation (Manufacturing and Non- Manufacturing) – Advantages of Automation –PLC Introduction – Block Diagram of PLC–Principle of Operation–Modes of Operation–PLC Scan–Memory Organization– Input Module (Schematic and Wiring Diagram) – Output Module (Schematic and Wiring Diagram).

Types of Programming Devices – Comparison between Hardwire Control System and PLC System –PLC Types (Fixed and Modular) – Input Types – Output Types – Criteria for Selection of Suitable PLC – List of Various PLCs available.

764 - SRIPC

Unit–VPLC PROGRAMMING AND SCADA

Different Programming Languages – Ladder Diagram – Relay Type Instruction – Timer Instruction – ON Delay and OFF Delay Timer – Retentive Timer Instruction – Cascading Timers – Counter Instruction UP Counter – Down Counter – UP/DOWN Counter - Ladder Logic Diagram for DOL Starter, Automatic STAR-DELTA Starter - Rotor Resistance Starter and EB to Generator Change over System. Supervisory Control Data Acquisition System (SCADA) – Block Diagram of SCADA, Features and Functions of SCADA – Introduction to DCS.

TEXT BOOKS:

S.No	Name of the Book	Author	Publisher
1.	Control of Electrical Machines	S.K. Bhattacharya	New Age International Publisher, New Delhi

REFERENCE BOOKS:

S.No	Name of the Book	Author	Publisher
1.	Exposing Programmable Logic Controllers with Application	Pradeep Kumar, Srivastava	BPB Publications
2.	Industrial Motor Control	Stephen Herman	6 th Edition, Cengage Learning
3.	Practical SCADA for Industry	David Bailey, Edwin Wright	Newnes Publishers

E-learning resources :

EL1: https://youtu.be/y_JLlaHr8Tw
EL2: https://youtu.be/6Y_JUKuFaiw
EL3: <https://youtu.be/s7y4AlaiBl0>

UNIT : 1 CONTROL CIRCUIT COMPONENTS

OBJECTIVES:

After studying this chapter, the student will be able to:

- State the purpose and general principles of control circuit of motor control.
- Discuss the symbol, construction and operation of selector switch, drum switch, limit switch, pressure switch, temperature switch (Thermostat), float switch, zero speed switch and proximity switches.
- Discuss the construction and operation of Voltage relay, DC series current relay, frequency response relay, latching relay, phase failure relay and over current relays.
- Explain the operation of the pneumatic and electronic timers.
- Describe the purpose and operation of solenoid valve and solenoid type contactors.
- Describe the operation of a simple ON-OFF motor control circuit, Remote control operation and interlocking of drives.

Introduction:

Control devices are components that govern the power delivered to an electrical load. Motor control systems make use of a wide variety of control devices. The motor control devices introduced in this chapter range from simple pushbutton switches to more complex solid-state sensors. All components used in motor control circuits may be classified as either primary control devices or pilot control devices. A primary control device, such as a motor contactor, starter, or controller, connects the load to the line. A pilot control device, such as a relay or switch contact, is used to activate the primary control device. Pilot-duty devices should not be used to switch horsepower loads unless they are specifically rated to do so. Contacts selected for both primary and pilot control devices must be capable of handling the voltage and current to be switched.

Pushbutton:

Pushbutton switches are commonly used in motor control circuits to start and stop motors, as well as to control and override process functions. A push button operates by pressing a button that opens or closes contacts.



Figure 1.1 Symbol of Pushbutton

Construction:

Push button switch can be divided into two parts. One part is the mechanical actuator or operator and the second part is the contact block. The operator is the part of the pushbutton assembly that is pressed, pulled, or rotated to activate the push button's contacts. Operators come in many different colors, shapes, and sizes designed for specific control applications.

The contact block is the part of the pushbutton assembly that is activated when the button is pressed as shown in figure 1.2. The contact block contains sets of contacts that open and close when push button is operated. The normal contact configuration allows for one normally open (N.O) and one normally closed (N.C) set of contacts within a contact block. Abbreviations N.O. (normally open) and N.C. (normally closed) represent the state of the switch contacts when the switch is not activated.

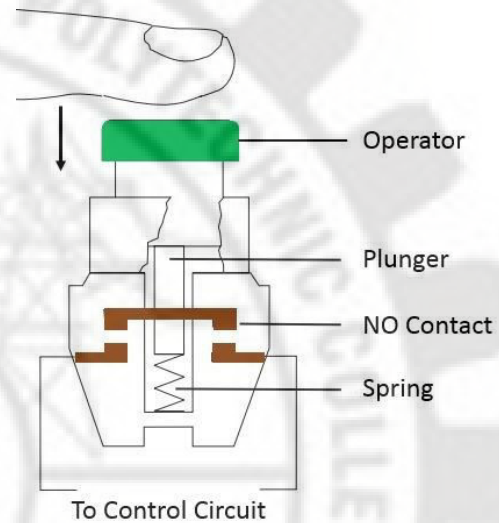

Figure 1.2 Construction of Pushbutton

Working:

When the button is pressed, NC contacts opens and NO contact closes. When the button is released a spring inside the actuators assembly brings back the push button and a spring inside the contact block brings the contacts back to their position.

The N.O. push button makes a circuit when it is pressed and returns to its open position when the button is released. The N.C. push button opens the circuit when it is pressed and returns to the closed position when the button is released.

Pushbutton operators are available for momentary and maintained operation. The momentary pushbutton switch is activated when the button is pressed, and deactivated when the button is released. The deactivation is done using an internal spring. The maintained pushbutton activates when pressed, but remains activated when it is released. Then to deactivate it, it must be pressed a second time.

Applications:

- i) ON/OFF switches in Motor starter
- ii) ON/OFF switches in TV, Computers and CRO etc.,

1.1.1 Pushbutton station:

When two or three push button switches are mounted on a steel or plastic enclosure it is known as a push button station. For example, in a three push button station, one push button may be for running the motor in forward direction, the second for running the motor in reverse direction, and the third for stopping themotor.



Figure 1.3 Pushbutton Station

SelectorSwitch:

A selector switch is a manually operated multi-position switch. It provides options to the operator to select a particular mode of operation.

Example: To Choose manual or Semiautomatic operation, Low Speed or High Speed etc.,

Construction:

As with push-button switches, selector switches also have two main parts, the mechanical actuator and the contact block. The difference between a push button and selector switch is the operator mechanism. A selector switch operator is rotated (instead of pushed) to open and close the contacts of the attached contact block. Such a switch is usually adjusted by a knob or handle. It is used to select the control from one position to other position. These switches may have two or more selector positions, with either maintained contact position or spring return to give momentary contact operation.

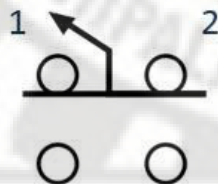

Figure 1.4 Symbol of Selector Switch



Figure 1.5 Selector switch

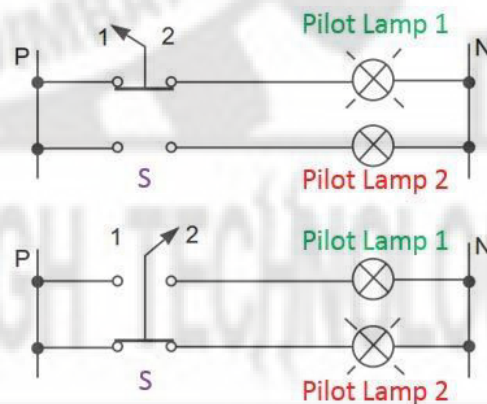

Figure 1.6 Circuit using Selector switch

The circuit of Figure 1.6 is an example of a two position selector switch used to select two different operating modes for control of two pilot lamps. In the example above, Pilot Lamp 1 is connected to the power source when the switch is in position 1, and Pilot Lamp 2 is connected to the power source when the switch is in position 2. In this circuit, either Pilot Lamp 1 or Pilot Lamp 2 would be ON at alltimes.

Applications:i) To change the control from the slow speed to high speed

ii) Automobile ignition switch

Drumswitches:

A Drum switch is a mechanically held device that allows the direction of rotation of a motor to be changed. It is also referred to as Master Controllers. It is identical in function but of a different type of construction than selector switches.



Figure 1.7 Drum Switch

Drum switch consists of a shaft attached to the operating lever, which has a number of cams mounted on it. It has set of moving contacts and a set of stationary contacts that open and close as the shaft is rotated. A single cam can operate two contacts, one mounted on right side and one on left side of the shaft cam arrangement. Reversing drum switches are designed to start and reverse motors by connecting them directly across the line.

Handle position		
Forward	Off	Reverse
1 ● —● 2	1 ● ● 2	1 ● —● 2
3 ● —● 4	3 ● ● 4	3 ● —● 4
5 ● —● 6	5 ● ● 6	5 ● —● 6

Figure 1.8(a) Handle Position

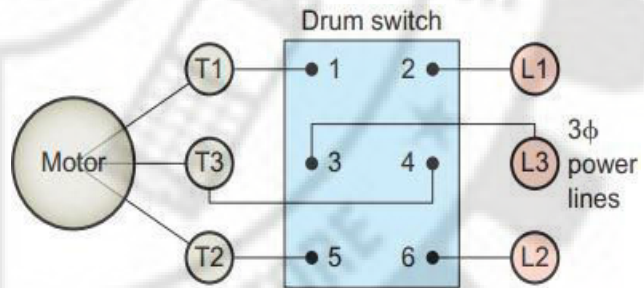

Figure 1.8(b) Circuit using Drum Switch

Figure 1.8 (b) shows how a drum switch is wired to reverse the direction of rotation of a three-phase motor. Reversal of the direction of rotation is accomplished by interchanging two of the three main power lines to the motor. The internal switching arrangements and resulting motor connections, for forward and reverse, are shown in the tables.

Applications: 1. Overhead cranes 2. Electric Train

Limit Switch:

Limit switches are designed to operate only when a predetermined limit is reached, and they are usually actuated by contact with an object such as a cam. Limit switches are constructed of two main parts: the body and the operator head (also called the actuator). The body houses the contacts that are opened or closed in response to the movement of the actuator. Contacts may consist of the normally open (NO), normally closed (NC), momentary (spring-returned), or maintained-contact types. A limit switch will change its output from NO to close or NC to open when an object is physically touching the switch. Limit switches come with a wide variety of operators such as lever type, Fork lever, Wobble stick, push roller type etc.,

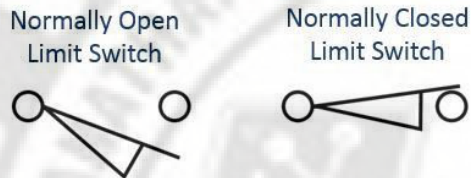

Figure 1.9 Symbol of Limit Switch

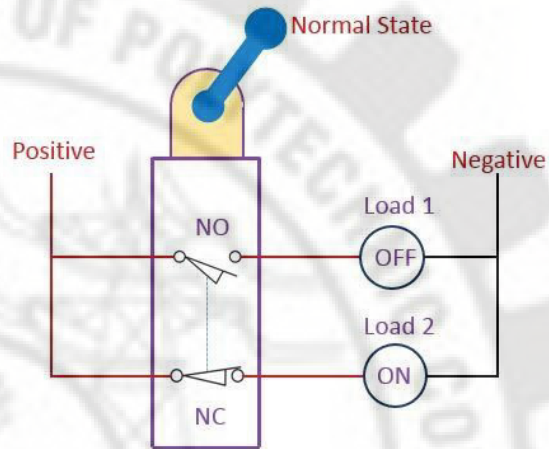

Figure 1.10 Circuit using Limit Switch

Working:

A contact block with one N.O. and one N.C. set of contacts is the most common configuration as shown in figure 1.10. When no external force is applied the actuator position is called as free position. When external force is applied or moving object is detected the actuator moves from free position to operating position. In the operating position the contacts of the limit switch change from their normal state (NO or NC) to their operated state.

Applications: 1. Lift 2. Cranes 3. Door switch

Pressure Switches:

Pressure switches are used to monitor and control the pressure of liquids and gases. They are commonly used to monitor a system and, in the event that pressure reaches a set point level, open relief valves or shut the system down. The pressure switches activate a set of contacts. The contacts may be either single pole or double pole depending on the application, and will be designed with some type of snap-action mechanism. Gas or liquid pressure can be used to actuate a switch mechanism if that pressure is applied to a piston, diaphragm, or bellows, which converts pressure to mechanical force.

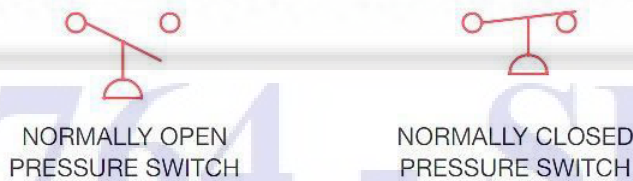

Figure 1.11 Symbol of Pressure Switch



Figure 1.12 Pressure Switch

The three categories of pressure switches used to activate electrical contacts are positive pressure, vacuum (negative pressure), and differential pressure.

Working:

The principle of working of bellow type pressure switch is illustrated in Figure 1.13. The bellow expands or contracts depending upon the pressure. The movement of the bellow tilts the lever which rests on the micro switch knob. The thrust of lever on the micro switch knob can be varied by adjusting the screw. This would change the pressure at which the micro switch contact will change over.

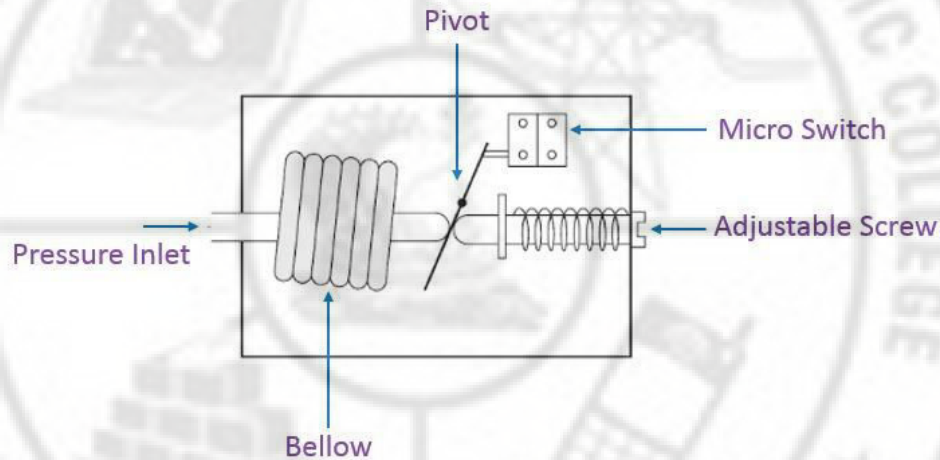

Figure 1.13 Bellow type pressure switch

Application with example:

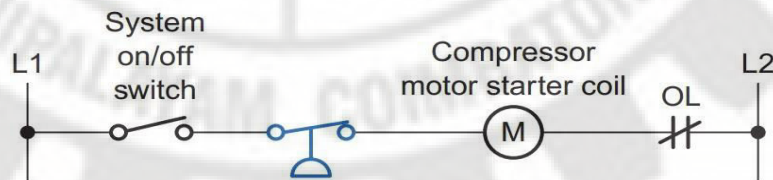

Figure 1.14 Circuit using Pressure Switch

For example if air pressure falls below the preset value, the contacts close and compressor motor is turned ON. If the pressure increases above the preset value, the contacts open and the compressor motor is turned OFF.

Application: Automobiles and Aircrafts

Temperature switch:

In many industrial processes temperatures have to be maintained within the limits. Temperature switches or thermostats are used for maintaining a prescribed value of temperature.

- Types:
1. Bimetallic strip type temperatureswitch
 2. Capillary type thermostat switch

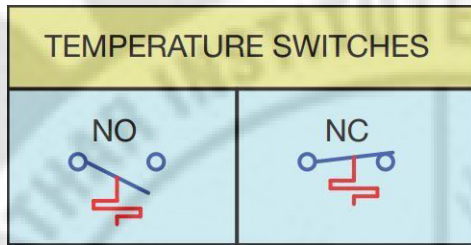

Figure 1.15 Symbol of Temperature Switch



Figure 1.16 Temperature Switch

Bimetallic strip type Temperature switch:

A temperature switch is a switch that is responsive to temperature changes. A bimetal strip of dissimilar metals is used as the sensing element for temperature sensitive switches. The unequal expansion of two bimetallic strips causes them to bend and this bending movement is used to actuate a snapswitch.

If a device gets too hot, the temperature sensitive switch opens the electrical circuit, thereby eliminating power to the circuit. Temperature sensitive switches are often used for thermal protection purposes.

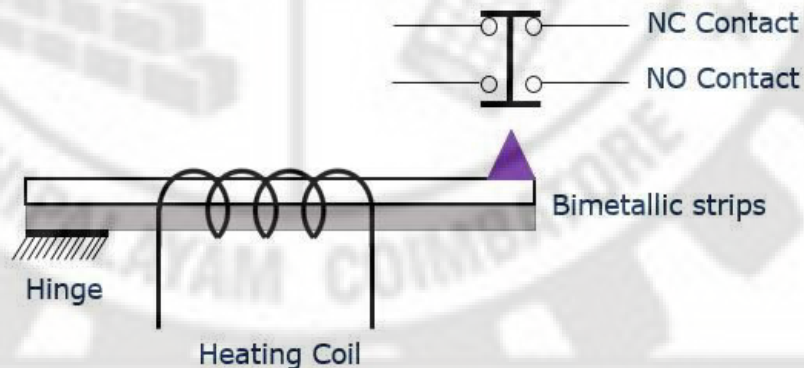

Figure 1.17 Construction of Bimetallic strip type temperature switch

Capillary type Thermostat:

The capillary tube thermostat uses the fluid either liquid or gas or vapour. The probe is located at the location where the temperature is to be measured. The fluid in the bulb expands and the pressure is developed in the bellows. The actuating pin actuates the contact operating mechanism.

Application:

- Electric heaters

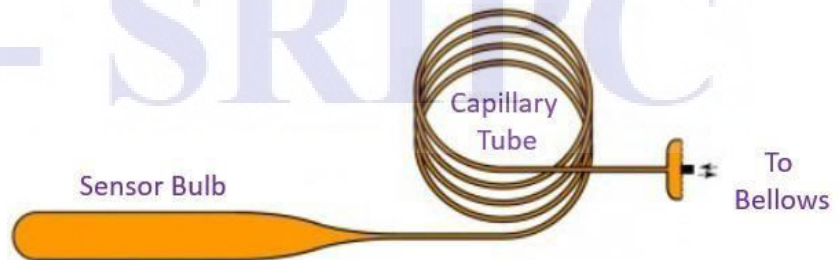

Figure 1.18 Capillary type Thermostat

Float Switch:

A float switch is used when a pump motor must be started and stopped according to changes in the water level in a tank or sump. The float switch allows for automatic operation of devices depending on the level of fluid, such as the operation of pumps, or the opening or closing of valves.



Figure 1.19 Symbol of Float Switch

Construction:

A float switch using a rod is shown in Figure 1.20. A float is attached to the lower end of the rod. The rod passes through a hole of a lever. Two stoppers fitted on two ends of the rod cannot pass through the hole. The float movement causes a rod operated to open or close electrical contacts. The float switch contacts may be either normally open or normally closed and may not be submerged.

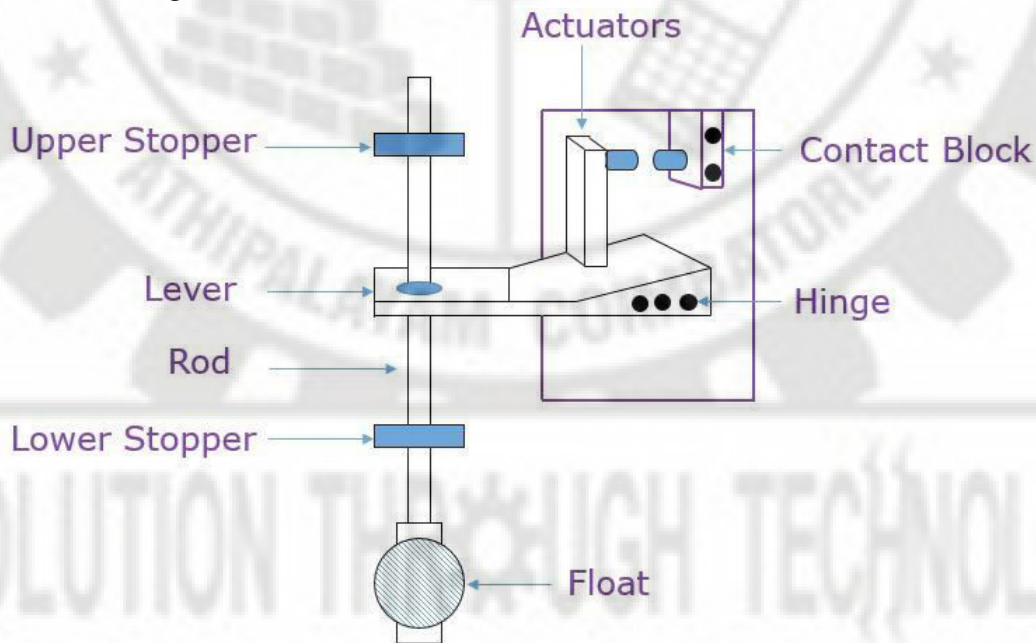

Figure 1.20 Construction of Float Switch

Working:

The operation of a float switch is controlled by the upward or downward movement of a float placed in a water tank. When the liquid level rises the float also rises and moves the rod up. At a certain level depending upon the position of lower stopper the lever gets tilted up and it in turn actuates the contact. When the water level starts falling the float and the rod also moves down. The lever, however, remains in the same position and keeps the contact actuated. At a

certain lower level depending upon the position of the upper stopper the lever gets tilted down by the stopper and the contact gets deactuated. When the liquid level starts rising the contact remains unactuated till the higher level set by stopper position is reached. This actuation and deactuation of the contact are used to stop and start a pump motor for maintaining the desired liquid level in the tank.

Applications: Tank liquid level control

Plugging switch or zero speed switch:

Plug switch is also called as the zero speed switch. A zero speed switch is physically coupled to a moving shaft of the motor.

As the zero speed switch rotates along with the machine, the centrifugal force causes the contacts of the switch to open or close, depending on its intended use. Each zero speed switch has a rated operating speed, within which the contacts will be switched.

These switches have two sets of contacts, one for each direction of rotation of the motor. The contacts for a particular direction of rotation open or close when a predetermined rotational speed in that direction is achieved. These switches are used in circuits where the motor is to be stopped quickly. In plugging, the motor is stopped by reversing its two supply leads till motor comes to standstill. The torque developed during reversing causes the motor to come to standstill in a short time.

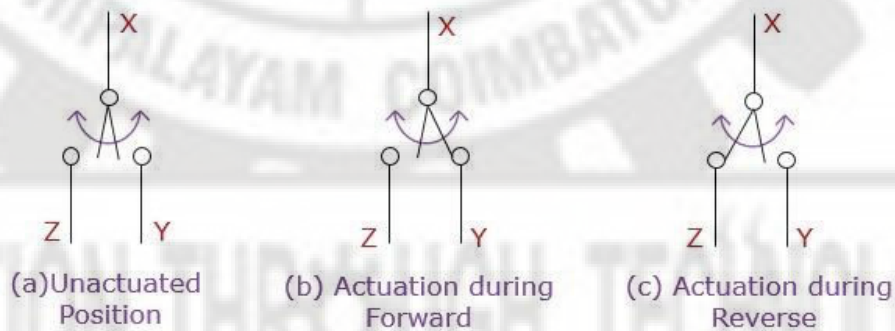

Figure 1.21 Plugging Switch or Zero Speed Switch

- When the motor runs in forward direction, X-Y contact gets closed.
- When the motor runs in reverse direction, X-Z contact gets closed.
- When the motor is in idle position, X-Y and X-Z are in open position.

Proximity Switch:

Proximity switch detect the presence of an object (usually called the target) without physical contact. Detection of the presence of solids such as metal, glass, and plastics, as well as most liquids, is achieved by means of a sensing magnetic or electrostatic field. These electronic

switches are completely encapsulated to protect against excessive vibration, liquids, chemicals, and corrosive agents found in the industrial environment.

Types:

1. Inductive Proximityswitch
2. Capacitive proximityswitch
3. Optical proximityswitch

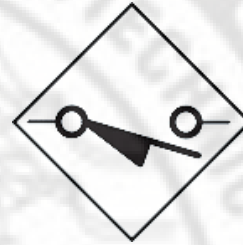

Figure 1.22 Symbol of NO Proximity Switch

Inductive proximityswitch:

It is a solid state switch based on the principle of high frequency electromagnetic induction. Inductive proximity sensors are used to detect both ferrous metals (containing iron) and nonferrous metals (such as copper, aluminum, and brass).

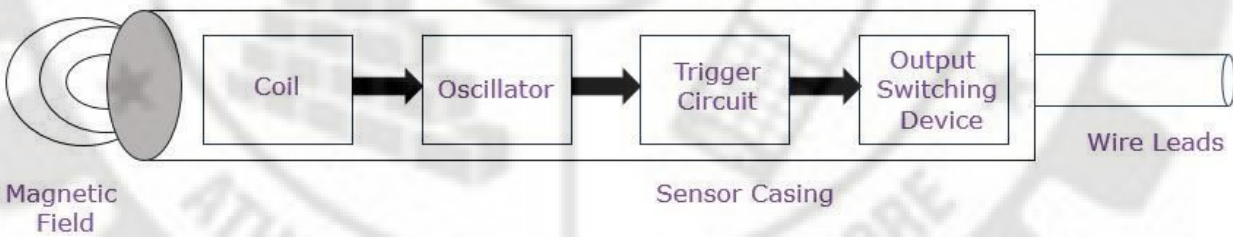

Figure 1.23 (a) Block Diagram of Inductive Proximity Switch

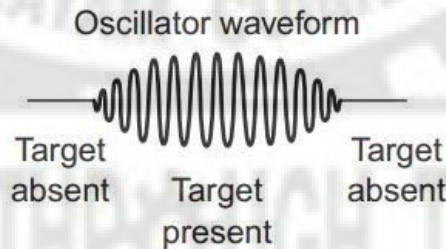

Figure 1.23 (b) Oscillator waveform of Inductive Proximity switch

The block diagram of inductive proximity sensor is shown in figure 1.23 (a). The oscillator circuit generates a high-frequency electromagnetic field that radiates from the end of the sensor. When a metal object enters the field, eddy currents are induced in the surface of the object. As the target moves nearer, the eddy current loss increases, which loads the output of oscillator. The sensor’s detection circuit monitors the oscillator’s strength and triggers a solid-state output to switch ON.

Capacitive proximityswitch:

Capacitive proximity sensors will sense metal objects as well as non-metallic materials such as paper, glass, liquids, and cloth.

Capacitive proximity switches are similar to inductive proximity sensors. The main differences between the two types are that capacitive proximity sensors produce an electrostatic field instead of an electromagnetic field and are actuated by both conductive and nonconductive materials. Capacitive sensors contain a high-frequency oscillator along with a sensing surface formed by two metal electrodes.

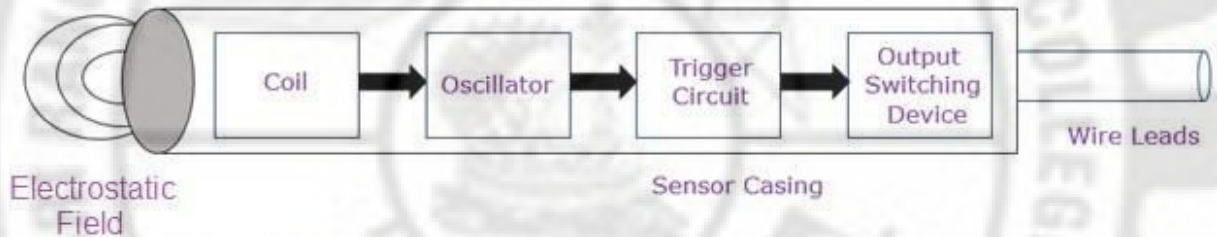

Figure 1.24 Block Diagram of Capacitive Proximity Switch

When the target nears the sensing surface, it enters the electrostatic field of the electrodes and changes the capacitance of the oscillator. As a result, the oscillator circuit begins oscillating and changes the output state of the sensor when it reaches certain amplitude. As the target moves away from the sensor, the oscillator's amplitude decreases, switching the sensor back to its original state.

Relays:

A relay is an electromechanical switch. It allows a low current control circuit to make or break an electrically isolated high current circuit.

Construction:

The construction of a typical electromechanical relay is shown in figure. The basic relay consists of a coil or wire wound around an iron core. A set of contacts are attached with frame of the relay. One contact is spring loaded and movable and the other contact is fixed in place. The contacts are electrically isolated from the coil.

Working:

Relays are manufactured to operate from a DC or AC source. When a relay is energized, a magnetic field is created around the coil of the relay. The magnetic field attracts the movable contact, causing the contact to move. When the contact moves, the circuit between the movable contact and the fixed contact is closed. So it is an electromagnetically operated switch. When energizing current is removed from the relay, the spring causes the movable contact to move, opening the circuit with the fixed contact.

The most widely used function of a relay is allowing one type or magnitude of age to be switched with a different types or magnitude of voltage. For example, a relay rated at 12V, DC may be used to switch 230V AC. Recall that the contacts of a relay are electrically isolated from the coil.

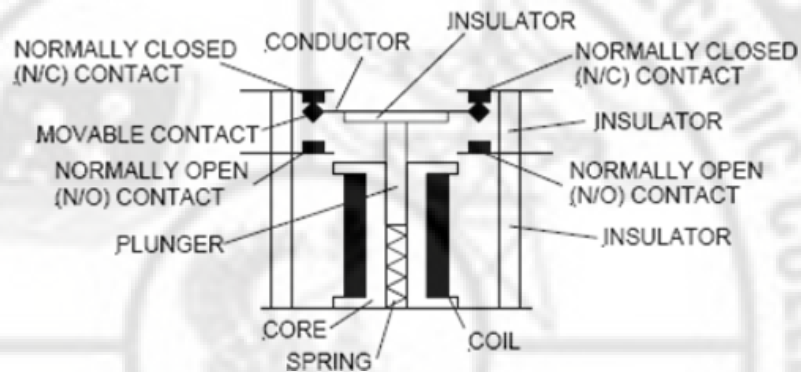

Figure 1.25 Relay or Contactor

Types of Relays:

- i. Voltage relay
- ii. DC Series current relay
- iii. Frequency response relay
- iv. Latching relay
- v. Phase failure relay (single phasing preventer).

Voltage relay:

A voltage relay is a relay that functions at a predetermined value of voltage. It may be either an overvoltage or an undervoltage relay. This is a small contactor which changes its contacts position from NO to Close or NC to open when a proper voltage is applied across its coil. The relay coil is generally designed to pick up at 85% of its rated coil voltage. If the voltage is less than 65% of rated voltage the operated contacts return to their unoperated position. This voltage is called as drop out voltage. This characteristic of relay is used to provide under voltage protection. This relay works on the fundamental principle of oersted's law.

Applications:

1. To switch ON the contactor
2. To switch OFF the contactor
3. It acts as the under voltage protection
4. Motor starter

DC Series Current Relay:

This relay changes its contact position in response to current change in its coil. The relay coil is connected in series with the circuit in which current change is to be sensed. It changes its

contacts position from NO to Close or NC to open when a current is flow through its coil. The relay coil is energized when the current flow through the coil reaches enough value to produce the necessary magnetic flux. This minimum value of current to energize the relay coil is known as pull in current. If the current is less than a predetermined value the operated contacts return to their unoperated position. This current is called as drop out current. DC series current relay is used as current limit accelerator in DCmotor.

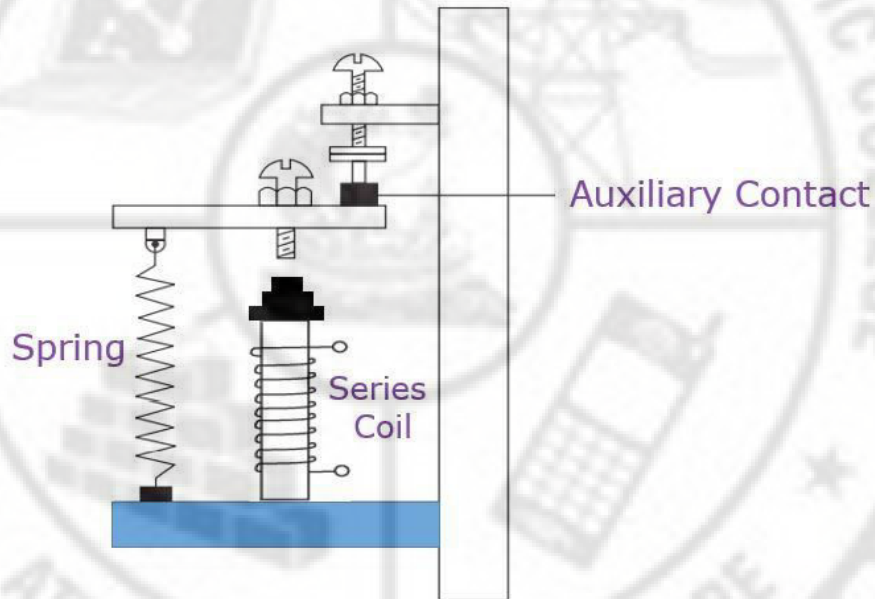

Figure 1.26 Series type Current Relay

Frequency resonserelay:

This type of relay changes its contacts position from operated position to unoperated position when the frequency of applied voltage falls below a predetermined value. The inductance of the relay and capacitor form a series resonant circuit. When the frequency falls below the resonant frequency, current through the relay coil falls and coil gets deenergized. The band width of the frequency range can be varied by changing the tapping of the potentiometer resistor.

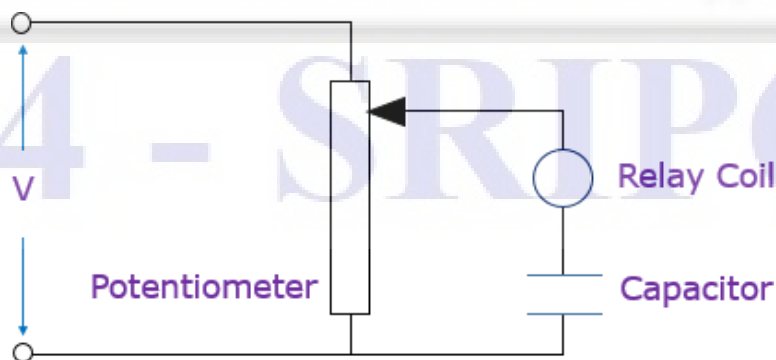

Figure 1.27 Frequency Responsive Relay

The frequency relays are used to apply field excitation to synchronous motors at the right instant and for acceleration control of wound rotor motors.

Latching Relay:

A latching relay consists of two separate coils and a mechanical linkage. One relay is called the Latch or Set coil and the other is called the Unlatch or Reset coil. When the latch coil is energized, the contacts change state. When the latch coil is energized the relay operates and is held in the energized position even when the latch coil is deenergized. This is a result of the mechanical linkage. To change the state of the contacts back to their original condition, the unlatch coil is energized. The contacts remain in their original condition after the unlatch coil is deenergized.

Two types of latching relays:

- i) Mechanical latched type
- ii) Permanent magnet type

Operation:

When supply is given to terminal 1 and neutral, latch coil is energized and current flows through D1 in the direction shown. Relay is actuated and held closed due to magnetization of the core even when supply is cut off. When relay closes, the contacts (L) open and disconnect the coil. When the relay is to be opened, supply is given between terminal 2 and neutral. Current in the unlatch coil flows through diode D2 in a direction so as to demagnetize the core. When the core gets demagnetized the relay opens and supply to unlatch coil is also disconnected through a normally open contact (UL) of the relay.

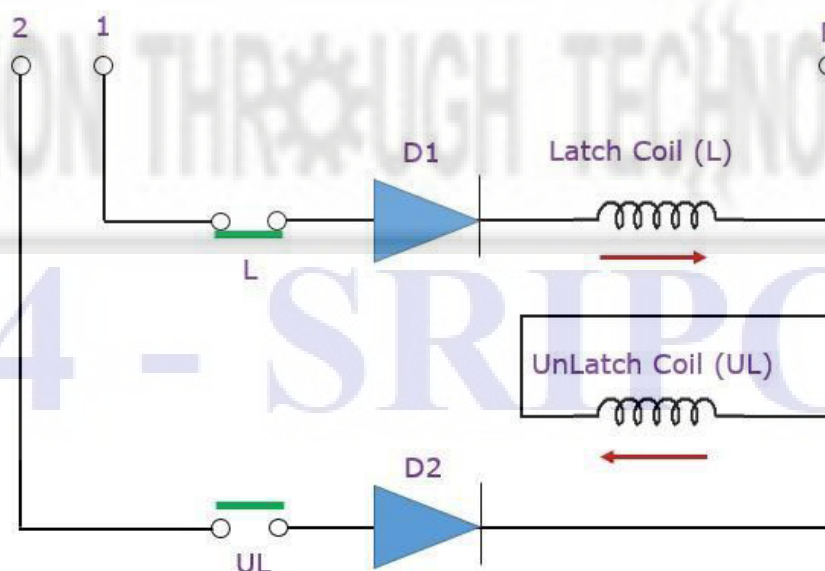

Figure 1.28 Latching Relay

Latching relays are often used as memory relays on machines or processes where the work on machine must start from where it stopped when the power had failed.

Phase failure relay: Single Phasingpreventer

In a 3 phase motor, when under running conditions, one of the three fuses blows and power to the motor is supplied by the remaining two phases, the motor is said to be running on single phasing condition. To maintain same power input to the motor during single phasing the current in the remaining two phases will increases by 1.73 times. If the motor is lightly loaded, currents in healthy phases will not increase beyond the full rated current setting on the overload relay. Thus overhead relay will not be able to detect single phasing when the motor is lightly loaded.

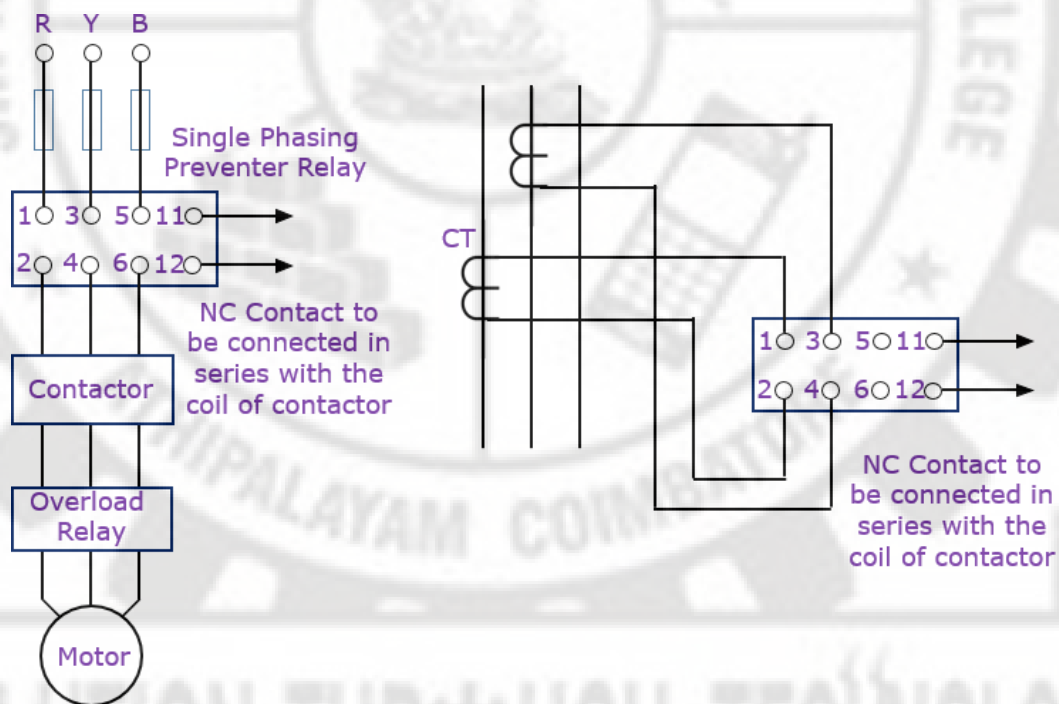

Figure 1.29 Single Phasing Preventer

The relay has two built in current transformers which sense currents of the motor. The secondary of the CTs feeds a negative sequence filter. The output from this filter is proportional to the negative sequence components of current. This output is fed to a sensor which detects the level of negative sequence components of current and thus trips the motor starter by opening its control contact.

Over Current Relay:

Overloads should not be confused with fuses or circuitbreakers. Fuses and circuit breakers are designed to protect the circuit from a direct ground or short-circuit condition. Over Current relays are designed to protect the motor from an overload condition. Motor may be overloaded due to mechanical overload or Low supply voltage or Single phasing. To protect a

motor against flow of excessive current an over load relay is connected in the power circuit. The relay is set at a certain value of current. When the, motor current exceeds this value the contact of the control relay opens after a time delay depending upon the relay characteristics. The over load relay has inverse time characteristics.

Types of Over Current or Load Relay:

- i) Thermal Overload Relay
- ii) Magnetic Overload Relay

Bimetallic thermal overload relay:

This is the most widely used relay because of its simple construction and minimum cost. The relay consists of bimetallic strips with current coils wound on them as shown in figure 1.30. Upper ends of strips are fixed strips while lower ends are free to move. It operates on the principle of converting motor current into a proportionate amount of heat. The current coil heats the bimetal strip when motor current flows through it.

When the temperature of the strips increases due to over load current, the strips bend towards right side. Now the tripping mechanism gets actuated and opens the relay contact. More is the current flowing through the coils; faster will be the action of the relay (inverse time characteristics). Tripping current is adjusted by adjusting the knob provided.

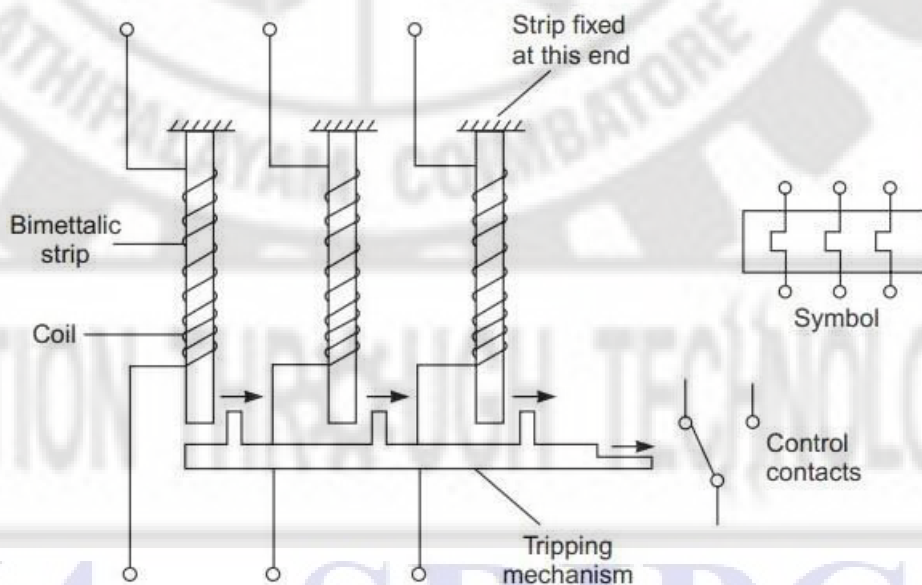

Figure 1.30 Bimetallic thermal overload relay

Magnetic dashpot oil filled relay:

Magnetic type overload relays operate by sensing the strength of the magnetic field produced by the current flowing to the motor.

The relay consists of a coil and the coil is connected in series with motor. A plunger is attached to the piston. This arrangement is immersed in the oil provided in the dashpot. When load current flows through the coil, magnetic field is set up around the coil. Hence the plunger will tend to rise up against gravity.

The piston has bypass holes of different sizes. When current through the coil increases, the plunger and the piston moves up. As the piston moves up, oil is forced through bypass holes which dampens the piston movements and provides delay. By varying the bypass holes, the delay characteristics of the relay can be varied. The relay provides inverse time characteristics. Tripping current is adjusted by adjusting the plunger position with respect to the relay coil. The magnetic dashpot relays are used in controlling largemotors.

The greatest difference between magnetic type and thermal type overload relays is that magnetic types are not sensitive to ambient temperature. Magnetic type overload relays are generally used in areas that exhibit extreme changes in ambient temperature.

Timer:

A relay with a built-in time delay device that causes the relay to either switch ON after a time delay, or to switch OFF after a time delay. These types of relays are called Time Delay Relays (TDR). Timer can be of ON delay or OFF delay type.

ON delay timer:

A timer is referred to as an ON delay type if the contacts change over after a preset delay after energisation.

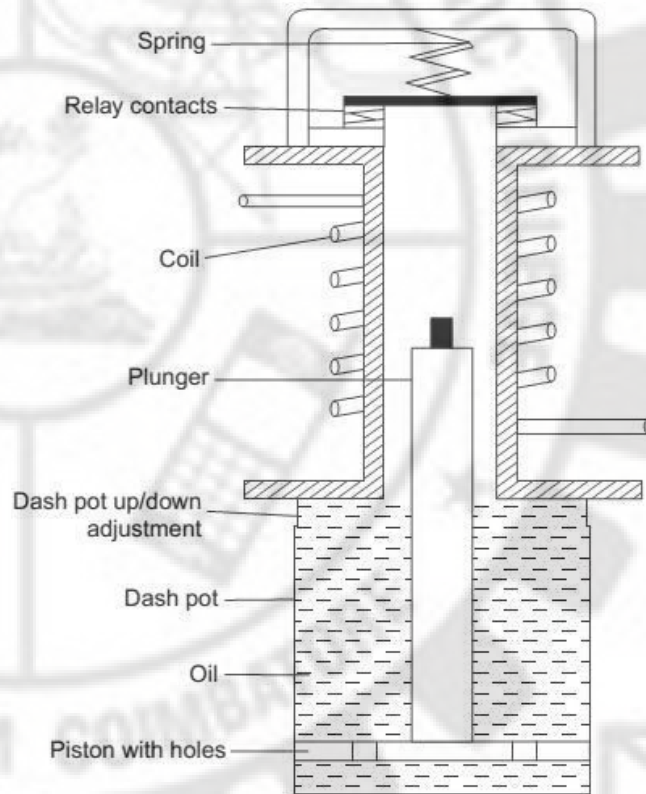

Figure 1.31 Construction of Magnetic dashpot oil-filled relay

(or)

The on-delay timer is often referred to as DOE, which stands for “Delay On Energize.”

OFF delay timer:

A timer is referred to as an OFF delay type if the contacts change over after a preset delay after deenergisation.

(or)

The off-delay timer is often referred to as DODE, which stands for “Delay On De-Energize.”

Thermal timer:

Principle of working a thermal timer is the same as that of a bimetallic overload relay. The time it takes to heat the bimetal strip produces the timing delay. These are available in the range of 0-20 seconds. The timing error is very large. Due to higher timing error thermal timers are used only in star delta starter. A type of analog timer that uses heat generated from an electric current to bend a bimetal strip, which closes a set of normally open contacts.

Pneumatic timers:

Pneumatic timer is an air-logic device used to provide a time-delay in a pneumatic system. It consists of solenoid coil, a plunger assembly, NO/NC contacts and air chamber. The air chamber is divided into upper air chamber and lower air chamber by a diaphragm. The diaphragm is attached to an operating rod and disc D as shown in figure 1.32. There is a provision of air flow from upper chamber to lower chamber through needle valve.

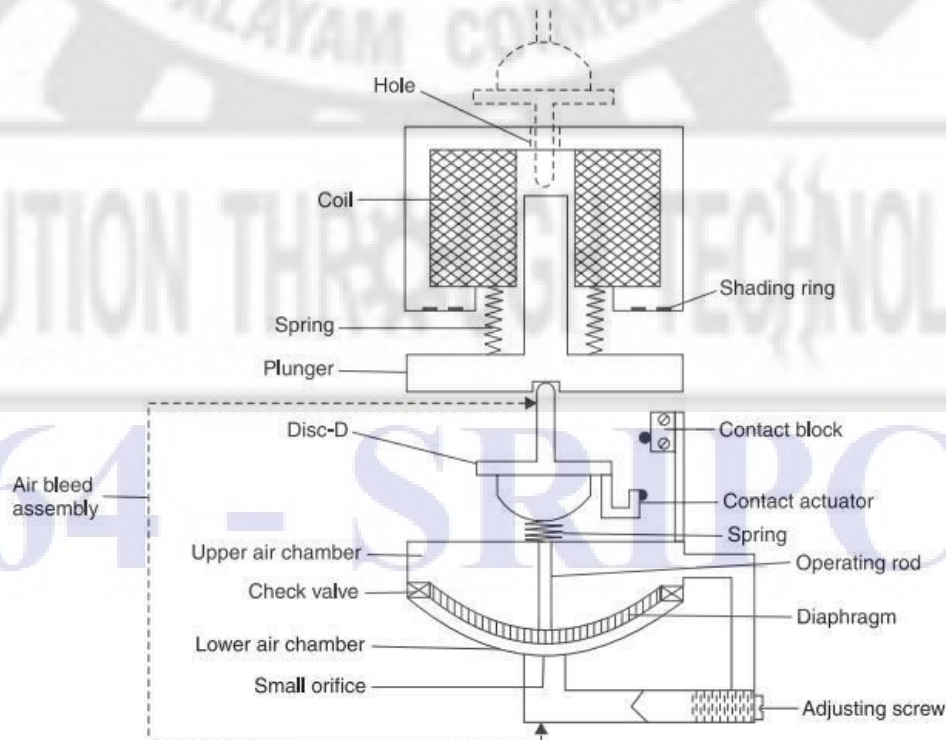

Figure 1.32 Construction of Pneumatic Timer

Operation:

Before the coil is energized the diaphragm is in its down position. When the solenoid coil is energized, the pressure on the disc (D) and the operating rod is released. Now the diaphragm is free and air leaks from upper to lower air chamber through needle valve. Now the diaphragm moves up till air pressure in both the chambers is equal. After this time delay the actuating lever attached to the disc will operate the NO/NC contacts. The time delay can be varied by adjusting the needle valve.

Pneumatic Timer Applications

1. Filling processes
2. Dairies
3. Vacuum pumping
4. Oil and gas industries, etc.



Timer Symbol	Delayed Contacts		Instantaneous Contacts
ON Delay or OFF Delay	ON Delay Timer	OFF Delay Timer	
			

Figure 1.33 Symbol of ON delay and OFF delay Timer

Electronic timer:

Electronic timers consists of an electronics circuits to introduce time delay. Electronic timers are generally of the ON delay type. A very simple electronic timer circuit using SCR is shown in figure. It consists of step down transformer, diodes and RC charging circuit. The transformer and diodes D_1 & D_2 are used to provide 12V DC supply to the electronic circuit. The coil of timer relay is connected in series with the SCR as shown in figure 1.34.

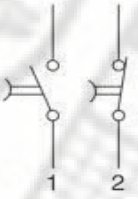
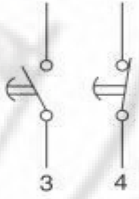
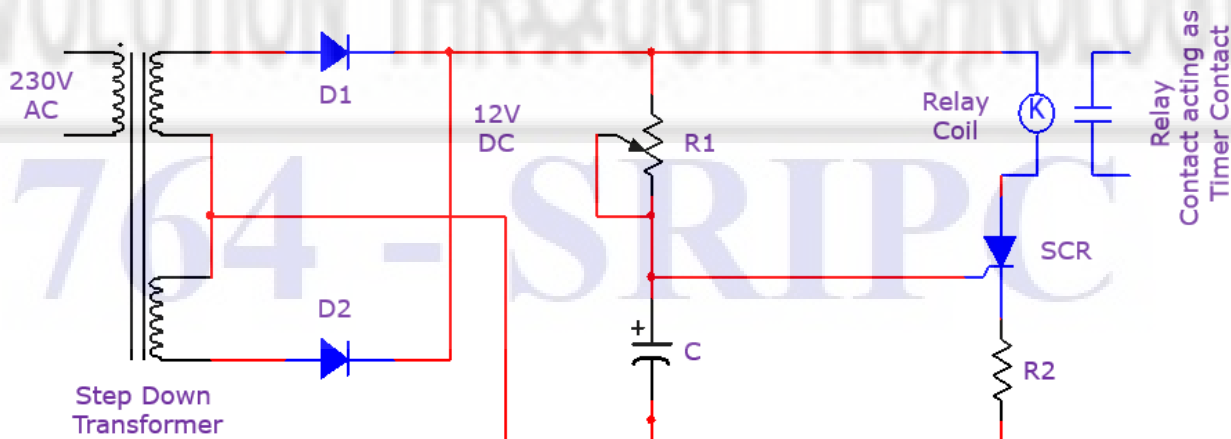

Figure 1.34 Circuit diagram of Electronic Timer

Operation:

When the main switch is closed, 12V DC supply is applied to RC triggering circuit and capacitor starts conducting. When the voltage across the capacitor is sufficient to turn ON SCR, the SCR starts conducting and timer coil gets supply and closes its contacts. By adjusting variable resistor R the time delay can be varied. The timer contacts return to normal position when the supply to the timer is cutoff.

Solenoidvalve:

Solenoid valves contain two distinct parts, the electrical part and the valve part. The electrical part consists of a coil of wire that supplies an electromagnetic field that operates the plunger or core. The valve body contains an orifice in which a disk or plug is positioned to restrict or allow flow.

When the solenoid coil is energized, the plunger is drawn into the coil and opening the valve as shown in figure 1.35. Solenoid valves can be closed when de-energized. If the valve is normally closed, it will open when the solenoid is energized. The plunger will return to its normal position when the solenoid is de-energized. Most valves contain a spring that re-seats the valve when de-energized. Some valves are normally opened and will close when energized. They will return to their normal open state when the solenoid is de-energized.



Figure 1.35 (a) Symbol of Solenoid Valve

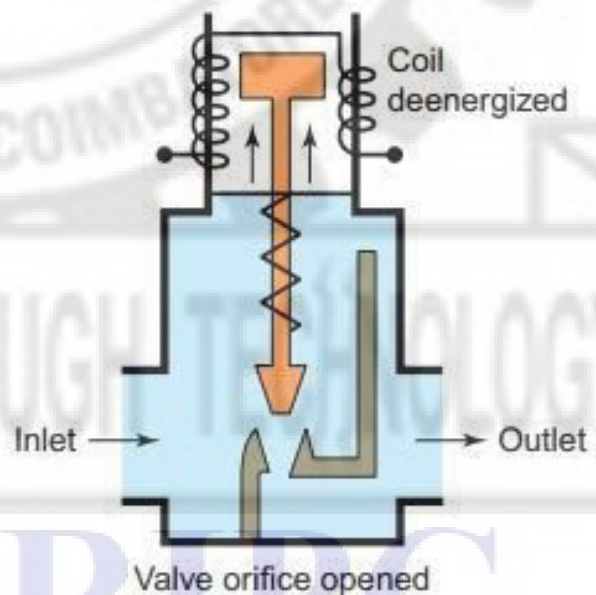

Figure 1.35 (b) Solenoid Valve

Solenoid valves may have two or more ports: in the case of a two-port valve the flow is switched on or off; in the case of a three-port valve, the outflow is switched between the two outlet ports.

Solenoid type contactor:

A relay with heavy duty contacts is called a contactor. Contactor is a magnetically closed switch. A contactor consists of a coil and set of NO/NC contacts. In this type the movable contacts are attached to the movable core of a magnet. When the electromagnet coil is energised, the movable core is pulled to the stationary core, thus closing the contacts. Fig. shows a solenoid type contactor. For better understanding, the contacts have been shown mounted in vertical plane though actually the contacts are in horizontal plane.

Mounting of contacts in horizontal plane reduces the size of the contactor. The position of plunger i.e., movable core shown in the figure is for the coil in de-energised state. When the coil is energised, plunger moves up, moving contacts mounted on plunger also moves up and closes the normally open contacts. At the same time normally closed contacts open. When the coil is de-energised contacts are broken and they come back to their normal position by the pull of gravity.

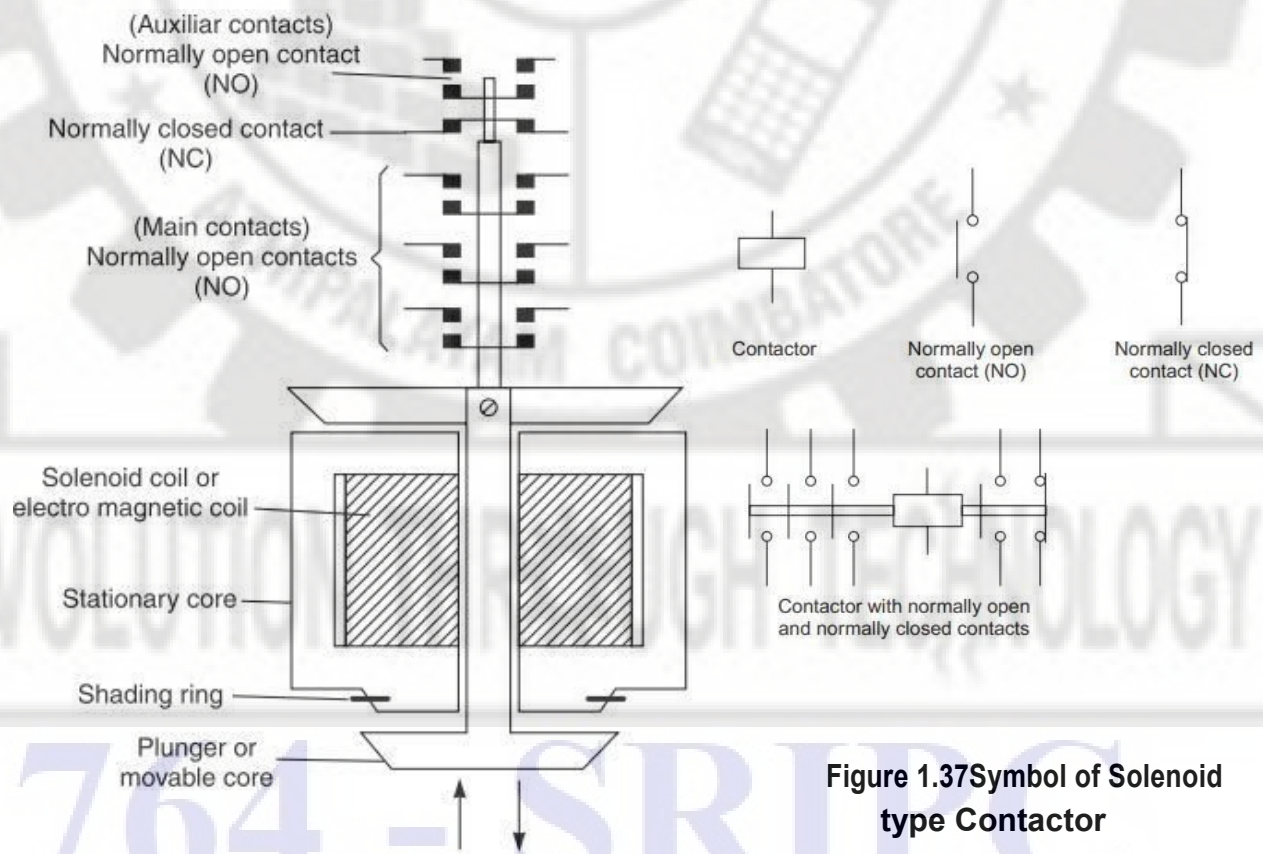

Figure 1.36 Construction of Solenoid type Contactor

Figure 1.37 Symbol of Solenoid type Contactor

The pole face of the magnet is provided with shading coil. The shading coil is used to prevent chattering of contactor. The solenoid type contactors are used for small ratings.

Solid state Relay:

A solid-state relay (SSR) is an electronic switch and it has no moving parts. Unlike electromechanical relays, SSRs do not have actual coils and contacts. Instead, it has semiconductor switching devices such as BJT, MOSFETs, SCR, or TRIAC. All SSRs are constructed to operate as two separate sections: input and output. The input side receives a voltage signal from the control circuit and the output side switches the load.

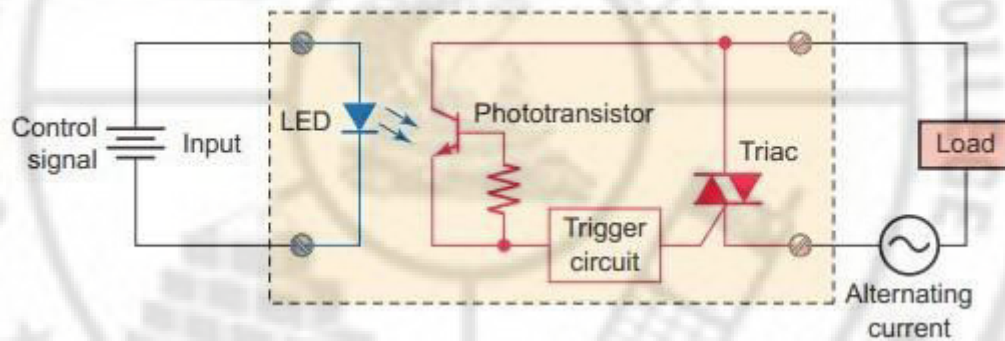

Figure 1.38 Circuit diagram of Solid State Relay

Working:

- ✓ When input signal is applied to LED, it will conduct and emits light on the phototransistor.
- ✓ The phototransistor conducts switching on the TRIAC and AC power to the load.
- ✓ The output is isolated from the input by the simple LED and phototransistor arrangement.
- ✓ Since a light beam is used as the control medium, no voltage spikes or electrical noise produced on the load side of the relay.
- ✓ The control side optically isolated from the load circuit.

Advantages of Solid state Relay:

1. No moving parts
2. Noiseless operation
3. Fast operation
4. Low power consumption
5. Compact and Less weight

Disadvantages of Solid State Relay:

1. Leakage current flow during OFF state
2. No electrical isolation

3. Small voltage drop across output contacts
4. High cost

Simple ON-OFF motor control circuit:

Simple ON-OFF motor control circuit consists of power or main circuit and the control circuit. Main circuit consists of main contact M_1 , M_2 and M_3 to control main supply. The control circuit consists of start push button, stop push button, sealing or holding contact and relay coil. The motor can be switched ON and OFF with the help of push buttons.

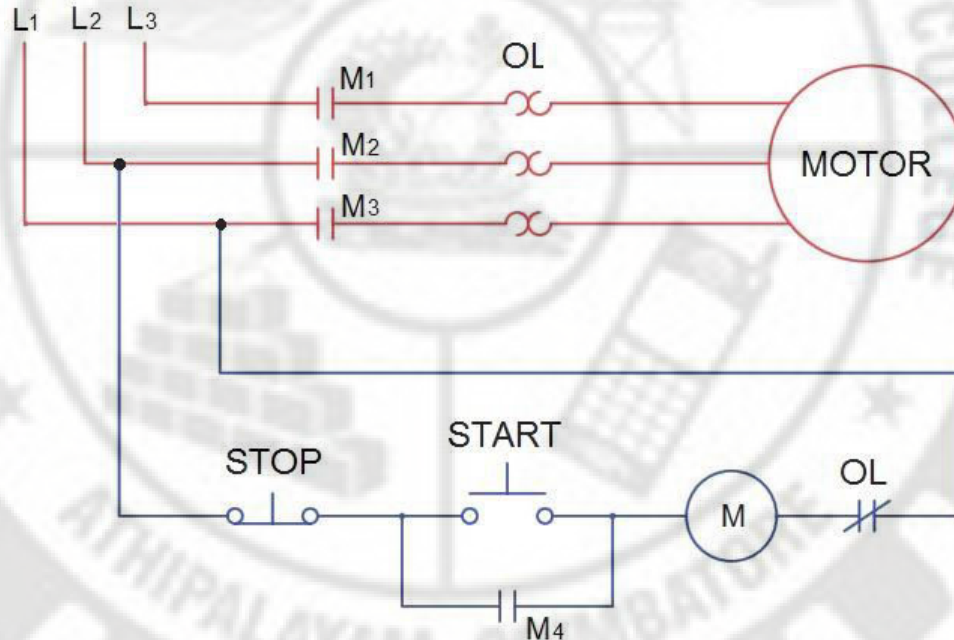

Figure 1.39 Simple ON-OFF motor control circuit

Sequence of operation:

1. When the Start push button is pressed, one of the terminal of Electromagnetic coil M is connected with supply through Stop push button and Start pushbutton.
2. The other terminal of the coil is connected through Normally Closed Over load contact 'OL' to the supply terminal. The coil is thus energised and contactor closes its main contacts M_1 , M_2 , M_3 and the auxiliary contact M_4 .
3. Closing of contact M_4 bypasses start push button. This contact M_4 is known as holding or sealing contact.
4. A bimetallic thermal over-load is also shown connected in the power circuit. If motor draws more current than its rated value, thermal relay contact OL opens and de-energises coil M.
5. When stop push button is pressed, coil M is de-energised and thus holding of supply through contact M_4 is broken.
6. Motor can be switched on again by pressing the START pushbutton.

Remote control of amotor:

Starting or stopping of motor from a remote location is called as remote control. Remote start push button is connected in parallel with local start button. The remote stop button is connected in series with local stop button.

The motor can be started and stopped from any number of locations by making connections as above. If the motor is to be started by some other pilot device like pressure switch, thermostat etc., the same may be made by connecting such a device in parallel with START-push button. If such a device is to be used for stopping also it is to be connected in series with the STOP-pushbutton.

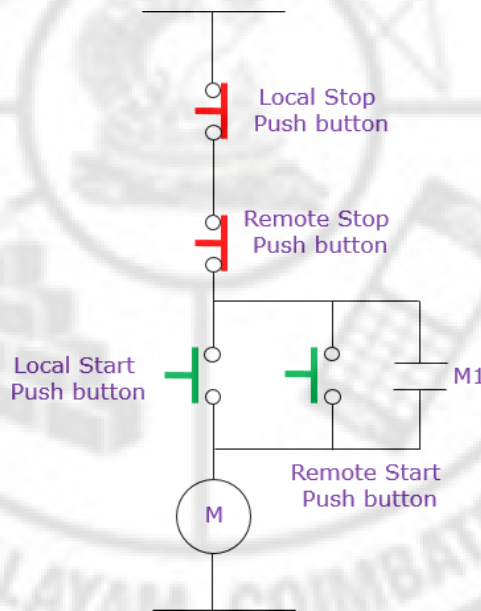

Figure 1.40Control circuit for Remote control of a motor

Interlocking of Drives:

Let us take motors *A* and *B*. It is required that motor *B* should start only after motor *A* has started. It should however be possible to stop the motor independently. In order that contactor *B* should energise only when contactor *A* is energised we will have to insert a normally open contact of contactor *A* in series with the contactor coil *B*. Thus when contactor *A* is not energised the

contact A_2 will be open. The contactor coil *B* can be energised only when contactor *A* is energised
 .. only when its contact A_2 is closed.

Interlocking of Drives

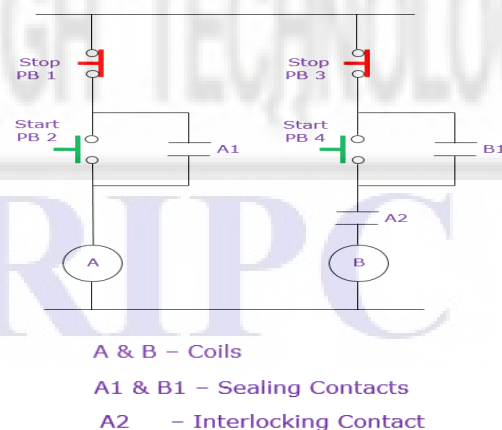

Figure 1.40Control circuit for Interlocking of Drives

UNIT – I CONTROL CIRCUIT COMPONENTS

MODEL QUESTIONS

Two Mark Question:

1. Draw the symbol of push button and selector switch.
2. List any two applications of push button switch.
3. List any two applications of selector switch.
4. Draw the symbol of drum switch and limit switch.
5. List any two applications of drum switch.
6. List any two applications of limit switch.
7. Draw the symbol of pressure switch and temperature switch.
8. List any two applications of pressure switch.
9. List any two applications of temperature switch.
10. Draw the symbol of float switch and temperature switch.
11. List any two applications of float switch.
12. List the two types of proximity switch.
13. Suggest suitable type of proximity switch to sense the presence of metal object.
14. Suggest suitable type of proximity switch to sense the presence of non-metal object.
15. Define voltage relay.
16. Define D.C. series current relay.
17. List the applications of latching relays.
18. What is frequency response relay?
19. Mention the exact situation where a frequency relay is used?
20. State the name of some relays used in control circuit.
21. What is single phasing?
22. What are the two basic types of overload relays?
23. What is the advantage of magnetic overload relay when compared to thermal overload relay?
24. What is OFF delay timer?
25. What is ON delay timer?
26. What is solenoid valve?
27. What is solid state relay?
28. State at least any two advantages of solid state relays.
29. What is meant by sealing contact?
30. What is meant by interlock contact?
31. How will you connect remote stop with local stop?
32. How will you connect remote start with local start?

Three Mark Questions:

1. Write short note on push button switch.
2. Write short note on selector switch.

3. Write short note on drumswitch.
4. Write short note on limitswitch.
5. Write short note on pressureswitch.
6. Write short note on temperature switch.
7. Write short note on floatswitch.
8. Write short note on zero speedswitch.
9. What is a zero speed switch and where is it used?
10. Write short note on proximityswitch.
11. Draw the block diagram of inductive proximityswitch.
12. Write a brief note on over loadrelay.
13. State the difference between thermal overload relay and magnetic overloadrelay?
14. Explain why thermal timers are used only in star-deltastarters.
15. Distinguish between ON delay timer and OFF delaytimer
16. Discuss the principle of operation of electronictimer.
17. What are the advantages of solid staterelay?
18. Draw the control circuit of simple ON/OFF motorcontrol.
19. Draw the control circuit of local and remotecontrol.
20. Explain the interlocking of drives in controlcircuit.

Ten Mark Questions:

1. With a neat sketch explain the construction and operation of Limit switch and Pressure switch.
2. Explain the construction and working of Push button and selector switch with neat diagram.
3. Explain the construction and working of drum switch with a neat sketch.
4. With neat sketch explain the automatic water level control using float switch.
5. Explain the following: a) DC series current relay b) Frequency response relay.
6. What is single phasing? With a neat sketch, explain the operation of single phasing preventer.
7. Explain the operation of current operated phase failure relay with a neat sketch.
8. Explain the construction and working principle of bimetallic thermal overload relay.
9. Explain the construction and working principle of magnetic dashpot oil filled relay.
10. With neat sketch explain the operation of pneumatic timer.
11. With neat sketch explain the operation of electronic timer.
12. Explain the construction and working of solenoid valve.
13. Explain the construction and working of a solenoid type contactor with a neat sketch.
14. Draw and explain,
 - (i) Simple ON-OFF motor control circuit.
 - (ii) Electrical Interlock.
15. Draw and explain the control circuit of LOCAL and REMOTE control.

UNIT: 2 MOTOR CONTROL CIRCUITS

OBJECTIVES:

After studying this chapter, the student will be able to:

- Identify the functional parts of a motor starter
- Explain the electrical interconnection and function of the control circuit and the power circuit
- Develop ladder diagram for Different types of starters, Forward and Reverse control, jogging control and dynamic braking and plug stop etc.,
- Follow common motor control circuits

Motor current at start and during acceleration:

Figure 2.1 shows the stator current Vs Speed curve when full voltage is applied to the stator of induction motor. From the current graph, it is noticed that the highest current draw is at locked rotor speed (Zero RPM). The starting current may be as high as 5 to 6 times the full load current of the motor. As the motor accelerates, the current goes on decreasing but a slow rate. The current decays sharply when motor reaches near its rated speed.

As shown in figure up to 50% of the rated speed the current is approximately 6 times the I_{FL} . At 80% of the rated speed the decline in the current is very fast. The motor heating rate is proportional to I^2R . Thus the rate of heating of the motor is high during acceleration.

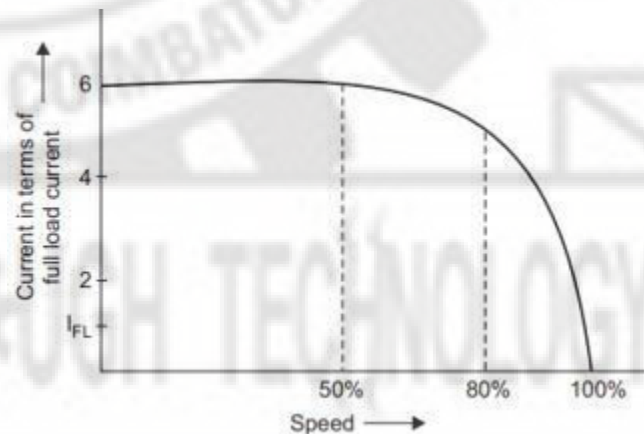

Figure 2.1 Current drawn by a three phase induction motor during starting

No-load speed and final speed of motor:

On no-load motor accelerates until the necessary speed is reached to overcome windage and friction losses. This speed is very near to the synchronous speed. When the motor is loaded, speed adjusts itself to the point where the force exerted by the magnetic field on rotor is sufficient to overcome the load torque. The difference between the speed of magnetic field and rotor is known as slip.

The slip of the motor varies also with variation in line voltage.

$V_L \uparrow \rightarrow \text{slip} \downarrow$ and $V_L \downarrow \rightarrow \text{slip} \uparrow$

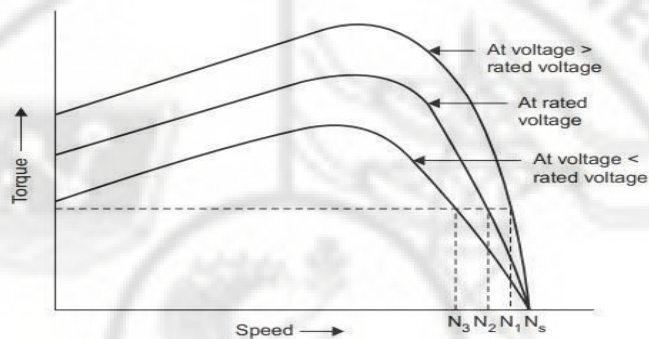

Figure 2.2 Torque speed characteristic of a three phase induction motor

Motor starter:

When a contactor is combined with an overload relay, it is called a **motor starter**.

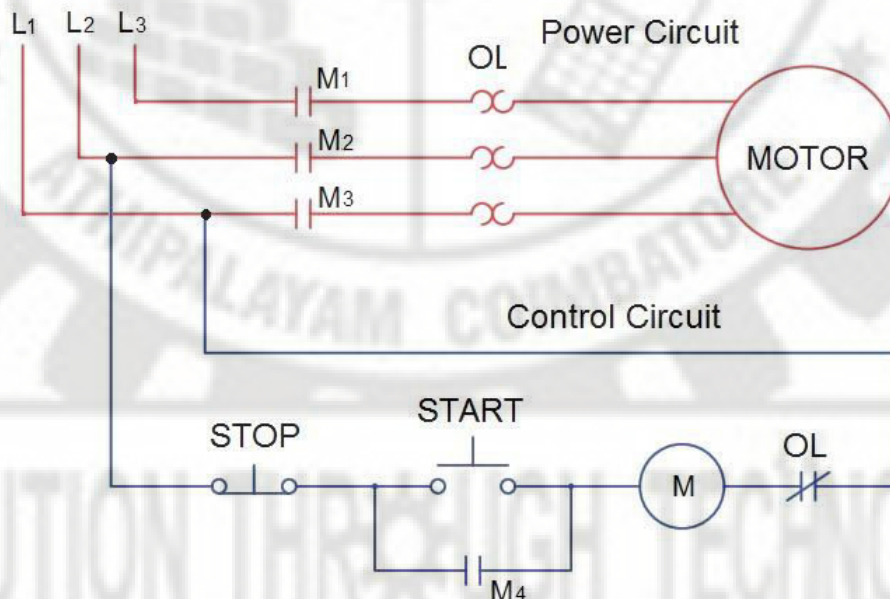

Figure 2.3 Power and Control circuit of Motor Starter

Power Circuit:

The power circuit distributes power from source to load. The current flow through the power circuit is the actual load current.

Control circuit:

Basic control circuits are used in starting, stopping, sequencing, and safety automatic interlocking of equipment and machines. The control circuit consists of relays, relay contacts, contactors, timers, counters, etc. Control circuit is used to control the distribution of power.

Current flow through control circuit is minimum which is the current taken by the electromagnetic relay or coil.

DOL Starter:

A full-line voltage is applied across the windings with this starter. DOL starter is suitable for induction motor of less than 5 hp. But the rating of motors which can be started direct-on-line depends on the capacity of the distribution system and the acceptable bus voltage drop during starting. The main circuit consists of main contacts (M_1, M_2, M_3), and an overload relay.

The control circuit consists of an NC contact of stop pushbutton, NO contact of start pushbutton and an overload relay NC contact, connected in series to the main contactor coil (M). The control supply for the circuit is connected across supply lines L_1 and L_2 .

Sequence of operation:

The main contactor coil gets the phase line (L_2) through the control circuit only when the start button is pressed. In this case, when the start pushbutton is pressed, the control circuit is closed and the main contactor (M) is energized and which closes its main contacts M_1, M_2 & M_3 and auxiliary contact M_4 .

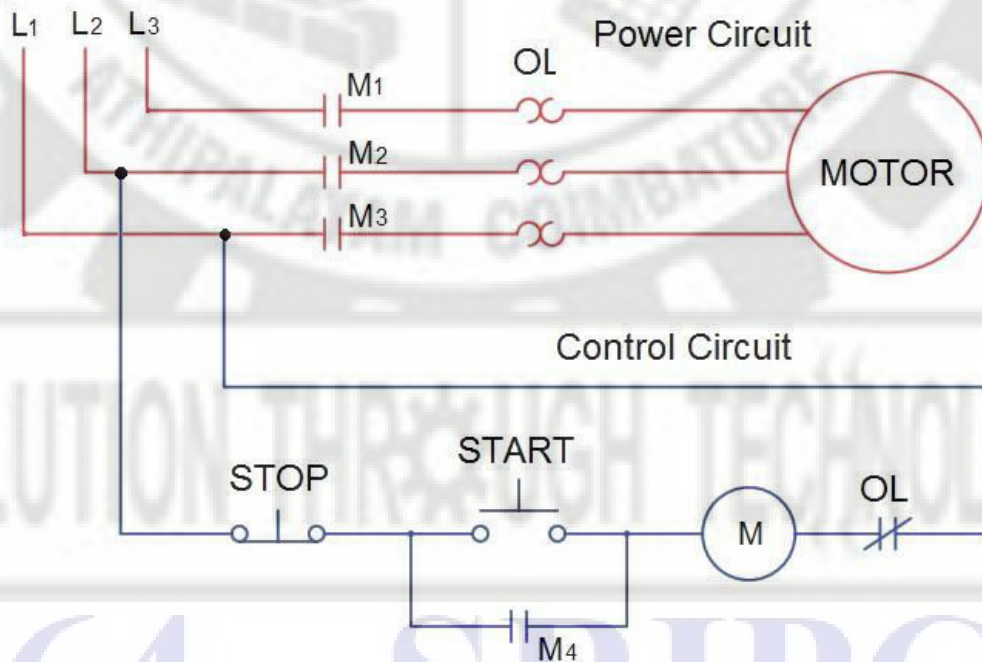

Figure 2.4 Power and Control circuit of DOL Starter

Now the motor is started with full line voltage and runs at rated speed. As the main contactor (M) is switched on, it is latched through this parallel NO contact (M_4) even after the start pushbutton is released. This arrangement is termed as latching or sealing or holding contact. When stop push button is pressed, M coil is deenergised and opens its contacts M_1 to M_4 and disconnect the supply to the motor. OLR is used to provide over load protection.

Auto Transformer Starter:

In this type of starter, autotransformer is connected between supply and motor terminal to reduce the starting current. The taps on the autotransformer limit the voltage applied to the motor to 50%, 65% or 80% of the nominal voltage. With autotransformer starting, the line current is always less than the motor current during starting because the motor is on the secondary of a transformer during acceleration. If a motor is connected to the 50% tap of the autotransformer, the motor current would be reduced to 50% of the normal starting value, but the line current would be only 25% of the normal starting current.

Since the motor starting current is greater than the line current with an autotransformer starter, the starter produces more torque-per-ampere of line current than any other type of reduced-voltage starter.

Auto transformer starters are of two types:

- i) Open circuit transition type
- ii) Closed circuit transition type

Automatic Auto Transformer Starter: Open transition

In Automatic Auto Transformer Starter, the transition from start to run condition takes place automatically with the help of a timer.

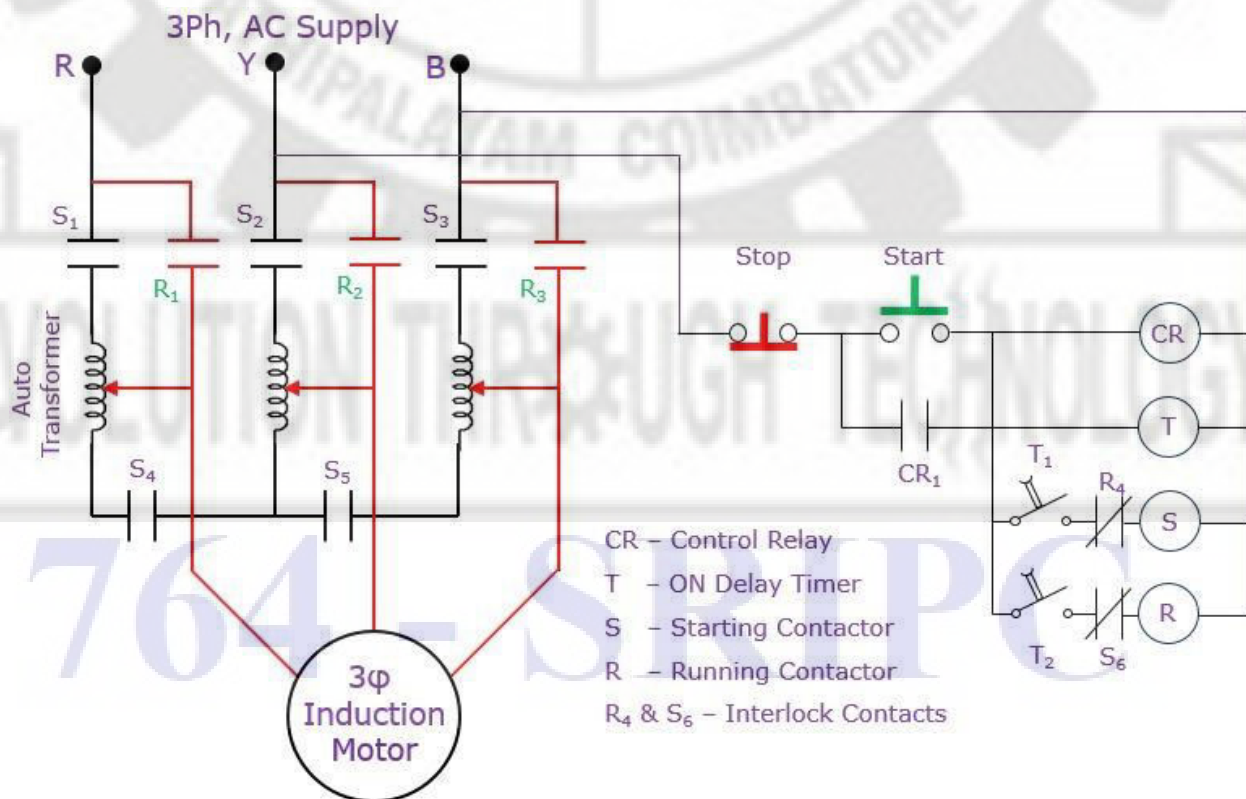

Figure 2.5 Power and Control circuit of Automatic Autotransformer Starter

Sequence of operation:

1. When START push button is pressed, CR is energized and sealed through CR₁.
2. S coil gets energized through CR₂ and T₁ and closes its NO contacts S₁ to S₅.
3. Now motor is started with reduced voltage.
4. NC contact of S coil is opened to prevent simultaneous energisation R coil.
5. After preset time, ON delay Timer T operates its NC contact T₁ opens and NO contact T₂ closes.
6. Opening of T₁ deenergises S coil and energises R coil.
7. Energised R coil closes its NO contact R₁, R₂ & R₃ and motor runs with fully voltage.
8. When STOP button is pressed, all the coils are deenergised to stop the motor.

In this type the motor is disconnected momentarily from the supply during transition from start to run condition.

Korndorfer Method of starting: closed circuit transition

In this type the motor is not disconnected from the supply during transition period. Less line disturbance and smooth acceleration are the advantages of closed transition type. This operation requires two 3 pole S coils.

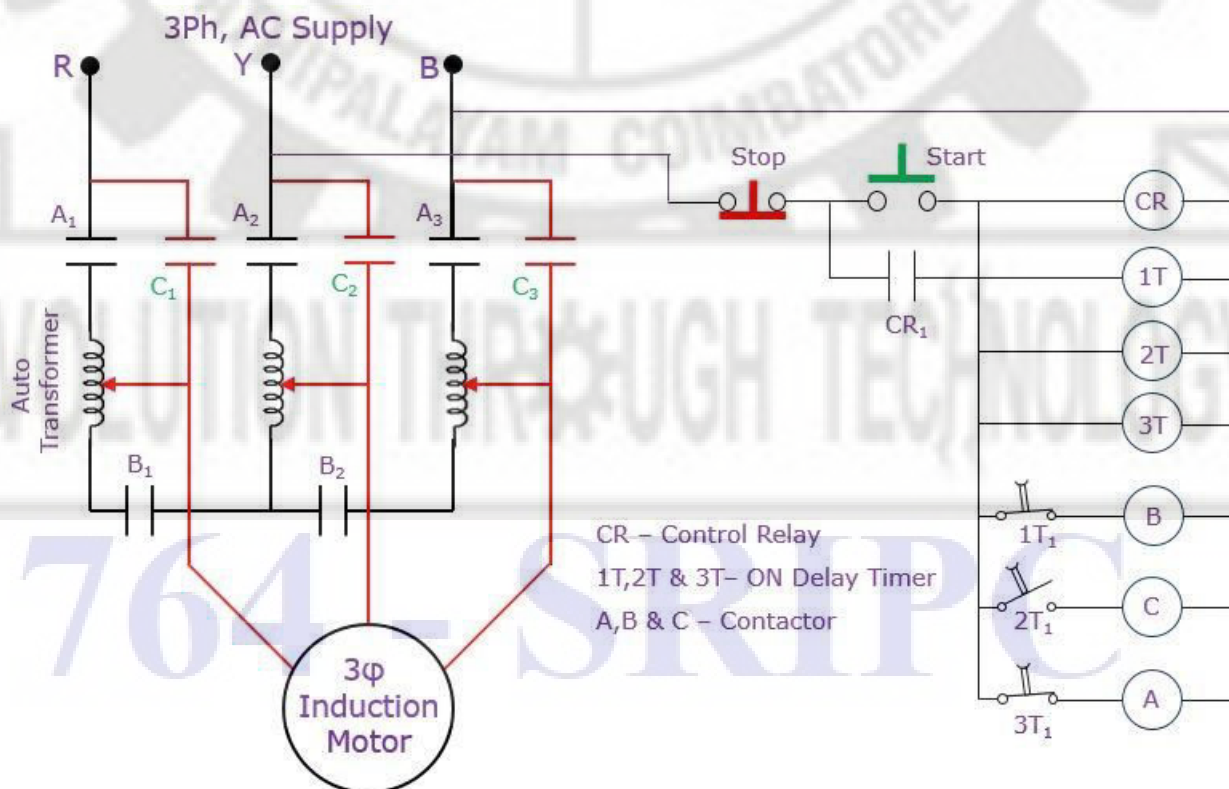

Figure 2.6 Power and Control circuit of Korndorfer Method

Sequence of operation:

1. When START push button is pressed, CR is energized and sealed through CR₁.
2. Timer TR₁, TR₂ & TR₃ are energized simultaneously through CR₁.
3. At the same time coil A & B are energized through NC contact TR₃ & TR₁ respectively.
4. NO contacts A₁, A₂, A₃, B₁, B₂ & B₃ are closed.
5. Now the motor is started with reduced voltage.
6. After preset time delay, coil B is deenergized due to opening of NC contact TR₁.
7. Still the motor is running with series reactor.
8. After preset time delay, coil C is energized due to closing of NO contact TR₂.
9. Now the series reactor is short circuited and full voltage is applied to motor.
10. After preset time delay, coil A is deenergized due to opening of NC contact TR₃.
11. During transition period the motor is not disconnected from the supply.
12. To stop the motor press, STOP push button.

Star delta starter:

Usually, a motor has the tendency to draw 200% to 500% higher current than the full load of normal current from the supply line during startup. This in turn increases the starting torque that is higher than normal, which can result in a mechanical damage. To avoid this, reduced voltage starters are used.

The starting current when using Star–delta starters is reduced by factor of 3 (i.e. 200% in place of 600%). The starting torque however also reduces by a factor 3. This method is therefore not suitable for loads with high inertia or those that require high starting torque. During starting it connects the stator windings of the motor in star connection. As the motor reaches near the rated speed, the windings connection are changed to delta.

Semi Automatic Star delta starter:

In semi-automatic star delta starter, the motor runs in star connection as long as ON push button is kept pressed. When ON push button is released the motor gets connected in delta.

Sequence of operation:

Press & hold START push button and observe the following sequence

1. Star coil S is energized through NC contact D₄.
2. Star coil contacts S₁, S₂, S₃ & S₄ get closed and stator windings are connected in STAR connection.
3. Main coil M is energized through S₄.
4. Main contacts M₁, M₂, M₃ & M₄ get closed.
5. Motor gets 3 phase supply and start with star connection.
6. M₄ act as sealing contact for M coil
7. S₅ act as the interlock so that D coil does not energise when S is energised.

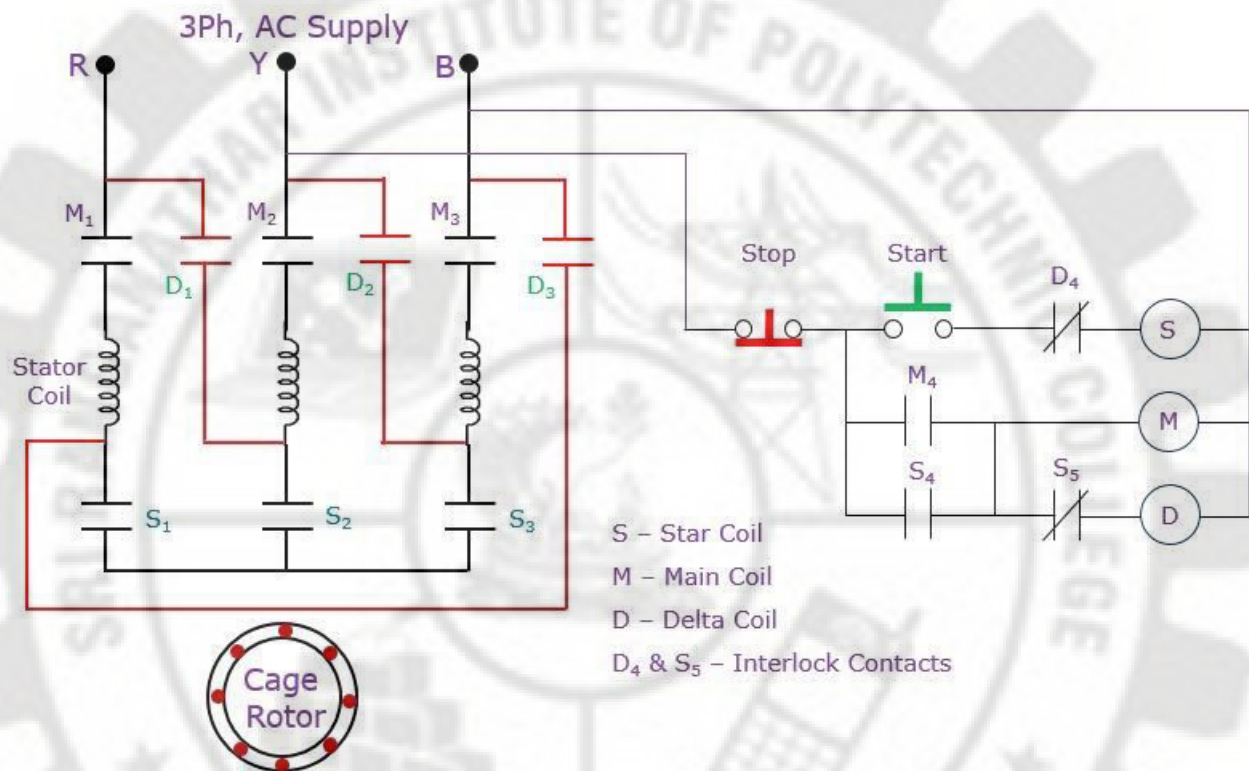

Figure 2.7 Power and Control circuit of Semi Automatic star delta starter

Release the START push button and observe the following sequence of operation.

1. S coil is deenergised
2. S₁, S₂, S₃ & S₄ is opened and S₅ gets closed.
3. Delta coil D is energised due to closing of S₅.
4. D₁, D₂ & D₃ gets closed and stator windings are connected in DELTA connection.
5. Now motor runs with delta connection.
6. D₄ act as the interlock so that S coil does not energise when D is energized
7. To stop the motor press STOP push button.

Automatic star delta starter:

In an automatic star-delta starter, the time required to change from star to delta connection is obtained with a time delay relay. A knob on the time delay relay can be adjusted at the desired time setting required for running the motor in star. ON delay Timer is used in the circuit as shown in figure 2.8.

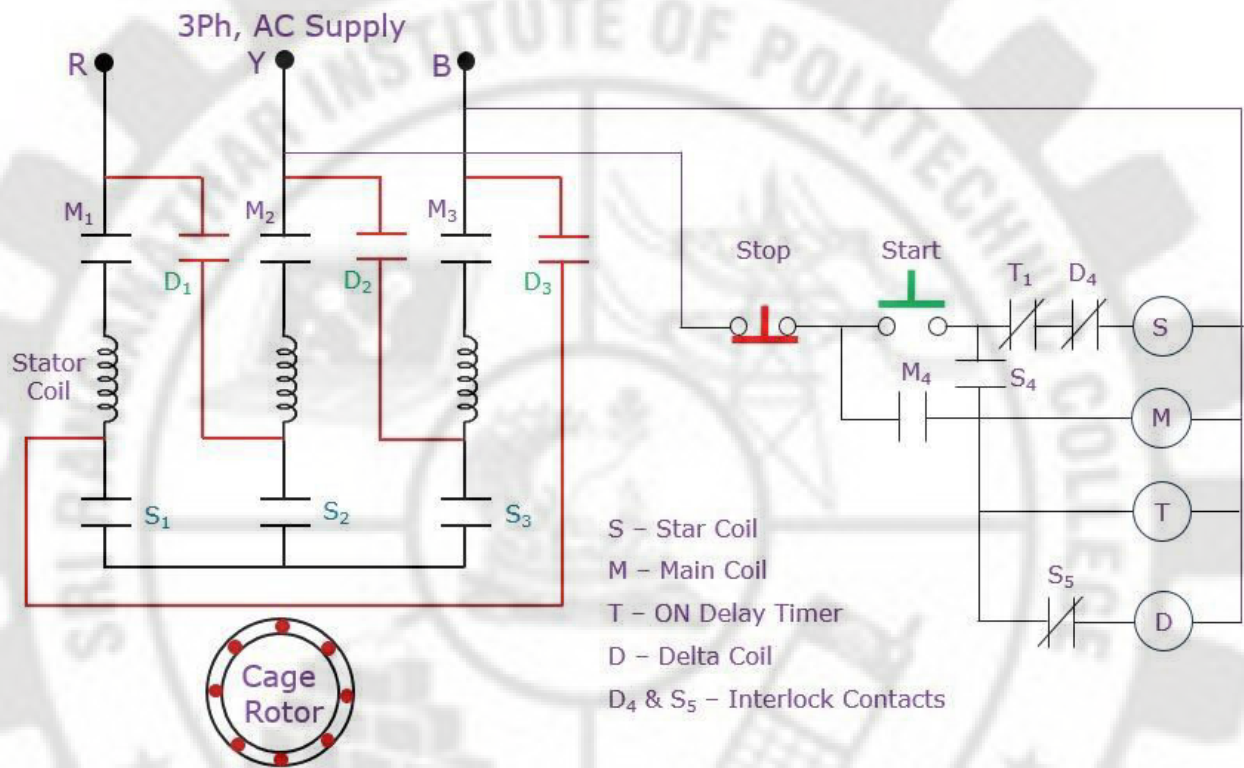

Figure 2.8 Power and Control circuit of Automatic star delta starter

Sequence of operation:

Reduced-voltage configuration (star configuration):

1. When start button is pressed, Star coil S is energized through NC contact D₄ & T₁.
2. Star coil contacts S₁, S₂, S₃ & S₄ get closed and stator windings are connected in STAR.
3. Main coil M and Timer T are energized through S₄.
4. Main contacts M₁, M₂, M₃ & M₄ get closed.
5. Motor gets 3 phase supply and runs with STAR configuration.
6. M₄ act as sealing contact for M coil
7. S₅ act as the interlock so that D coil does not energise when S is energized.

Full voltage (delta configuration):

8. After preset time delay timer contact T₁ is opened & S coil is deenergised.
9. S₁, S₂, S₃ & S₄ is opened and S₅ gets closed.
10. Delta coil D is energised due to closing of S₅.
11. D₁, D₂ & D₃ gets closed and stator windings are connected in DELTA configuration.
12. D₄ act as the interlock so that S coil does not energise when D is energized.
13. When the stop button is pressed all the contactors are deenergised to stop the motor.

Starter for two speed control:

In two speed control, the stator may be wound with two sets of winding for low speed and high speed.

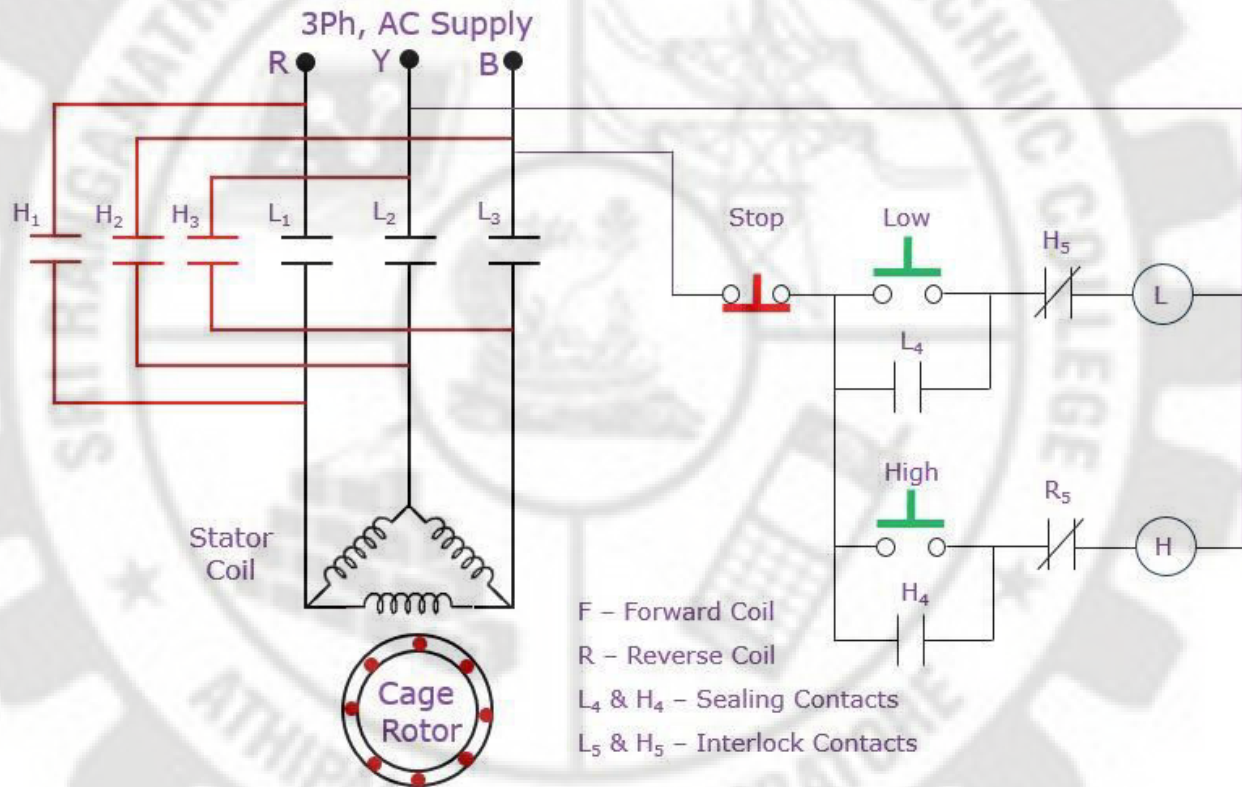

Figure 2.9 Power and Control circuit of Starter for Two Speed Control

Sequence of operation:

Press LS push button and observe the following sequence of operation.

1. Coil L is energised through H₅.
2. Contacts L₁, L₂, L₃ & L₄ get closed
3. Motor gets 3 phase supply and runs in low speed.
4. L₄ act as sealing contact & L₅ act as interlock contact.
5. Motor can be stopped by pressing STOP pushbutton.

Press HS push button and observe the following sequence of operation

6. Coil H is energised through H₅.
7. Contacts H₁, H₂, H₃ & H₄ get closed.
8. Motor gets 3 phase supply and runs with high speed.
9. H₄ act as sealing contact & H₅ act as interlock contact.
10. To stop the motor press STOP pushbutton.

Forward and Reverse control:

An interchange of any two phases reverse the direction of a three-phase motor. This will run the motor in the reverse direction. This starter consists of two contactors namely forward & Reverse contactor.

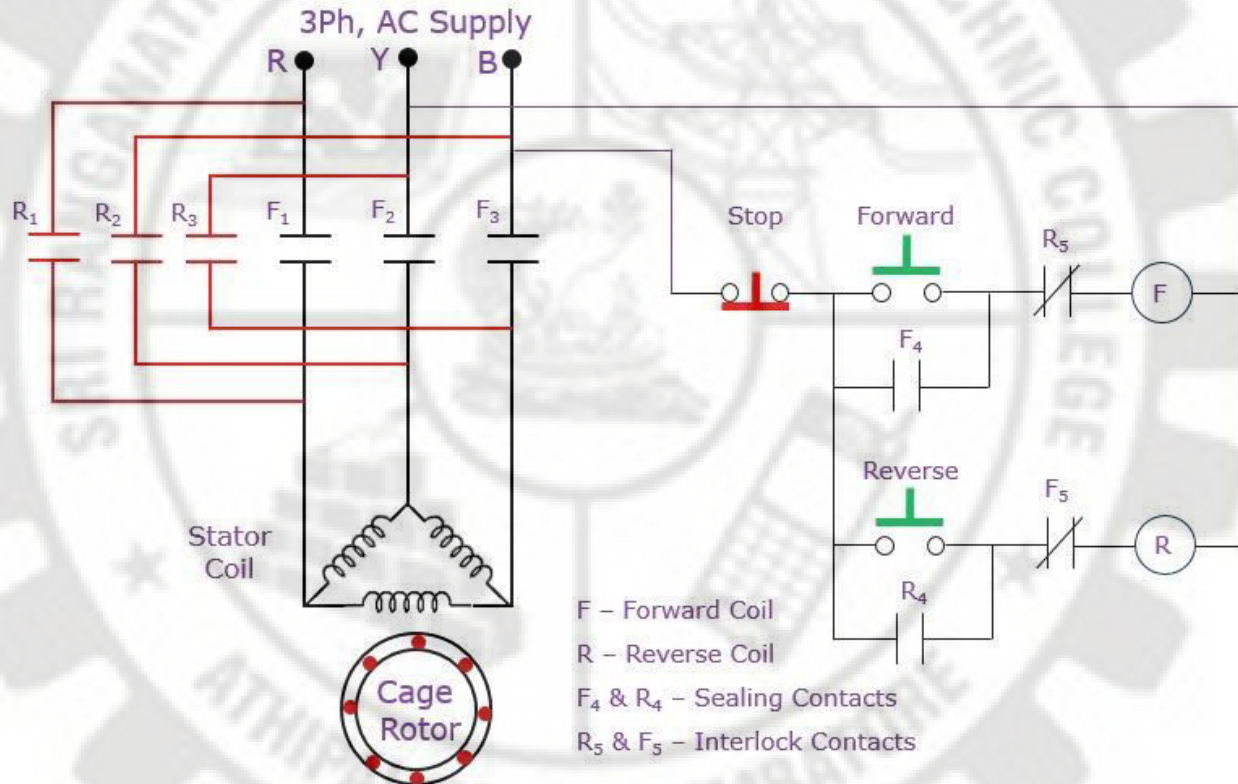

Figure 2.10 Power and Control circuit of Forward and Reverse Control

Sequence of operation:

Forward Direction:

Pressing the forward pushbutton will energize the Forward contactor coil (F). This in turn will close its contacts F₁, F₂, F₃ and F₄ and connect the supply leads to the motor leads. Now the motor gets 3 phase supply and runs in forward direction. The auxiliary contact F₅ act as interlock contact and keep the Reverse contactor coil circuit as open. The contactor F will remain energized because of the latching contact of F₄. The motor will continue to run in a forward direction until the stop/reverse pushbutton is pressed or the motor trips on overload.

Reverse Direction:

Pressing the reverse pushbutton will energize the Reverse contactor coil (R). This in turn will close its contacts R₁, R₂, R₃ and R₄ and connect the supply leads to the motor leads. Now the motor gets 3 phase supply and runs in reverse direction. The auxiliary contact R₅ act as interlock contact and keep the Reverse contactor coil circuit as open. The contactor R will remain energized because of the latching contact of R₄. The motor will continue to run in a reverse direction until the stop/forward pushbutton is pressed or the motor trips on overload.

Dynamic braking:

It is one of the methods of bringing the motor to a quick stop. In this starter, after disconnecting AC supply, a D.C. is applied to two lines of stator. The rotating rotor conductor cuts the flux produced by DC and thus emf is induced in the rotor. The mechanical energy due to inertia is converted into electrical energy and dissipated as heat to obtain braking effect.

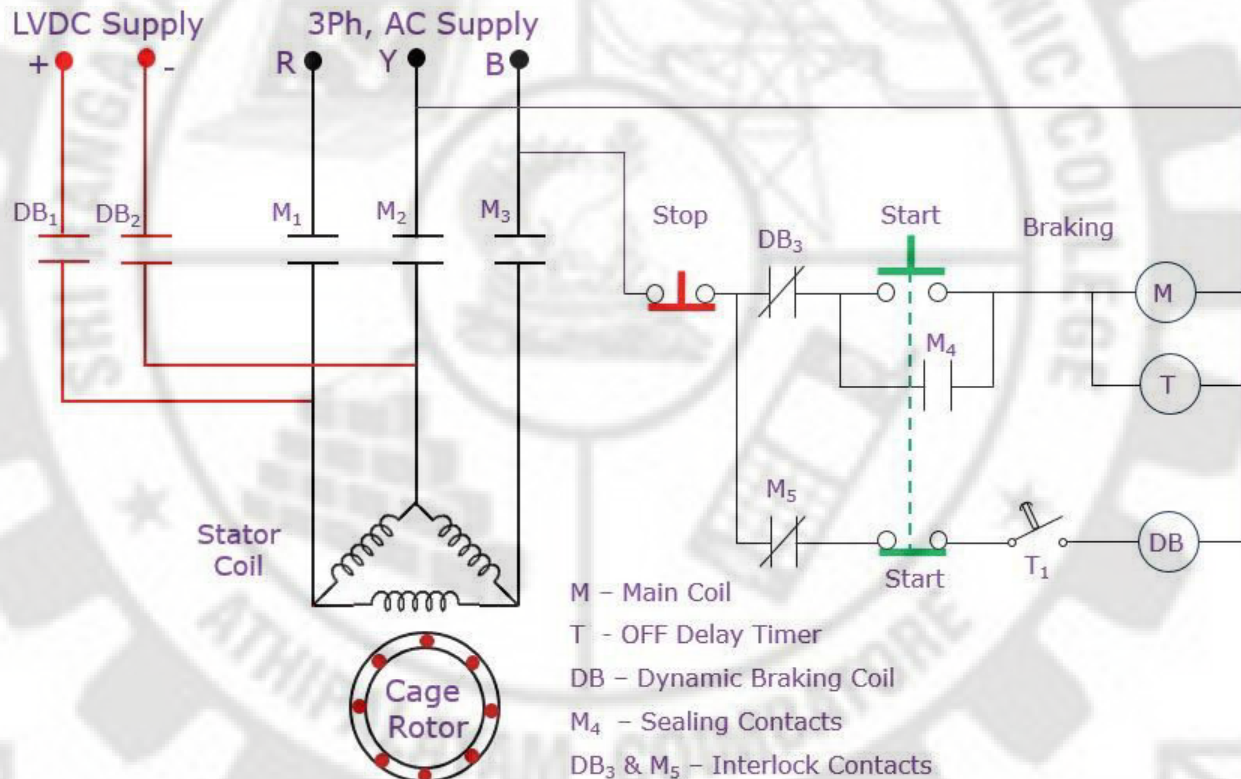

Figure 2.11 Power and Control circuit of Dynamic Braking

Sequence of operation:

1. When start push button is pressed, M coil & Timer is energized through DB₁.
2. Main contacts M₁, M₂, M₃ & M₄ gets closed and M₅ is opened.
3. Contact T gets closed immediately but contact M₅ prevents the energization of DB coil.
4. A semiconductor rectifier is included in the starter to provide a DC excitation.
5. When stop push button is pressed, M coil is deenergized and closes its NC contact M₅.
6. OFF delay timer Contact T remains closed for preset time.
7. Now DB coil is energized and closes its contacts DB₁ & DB₂.
8. Now DC supplied is applied to stator terminals.
9. It develops reverse torque and brings the motor to a standstill.
10. After preset time contact T is opened & DB coil is deenergized.
11. Now motor is ready for next operation.

Automatic Rotor Resistance Starter:

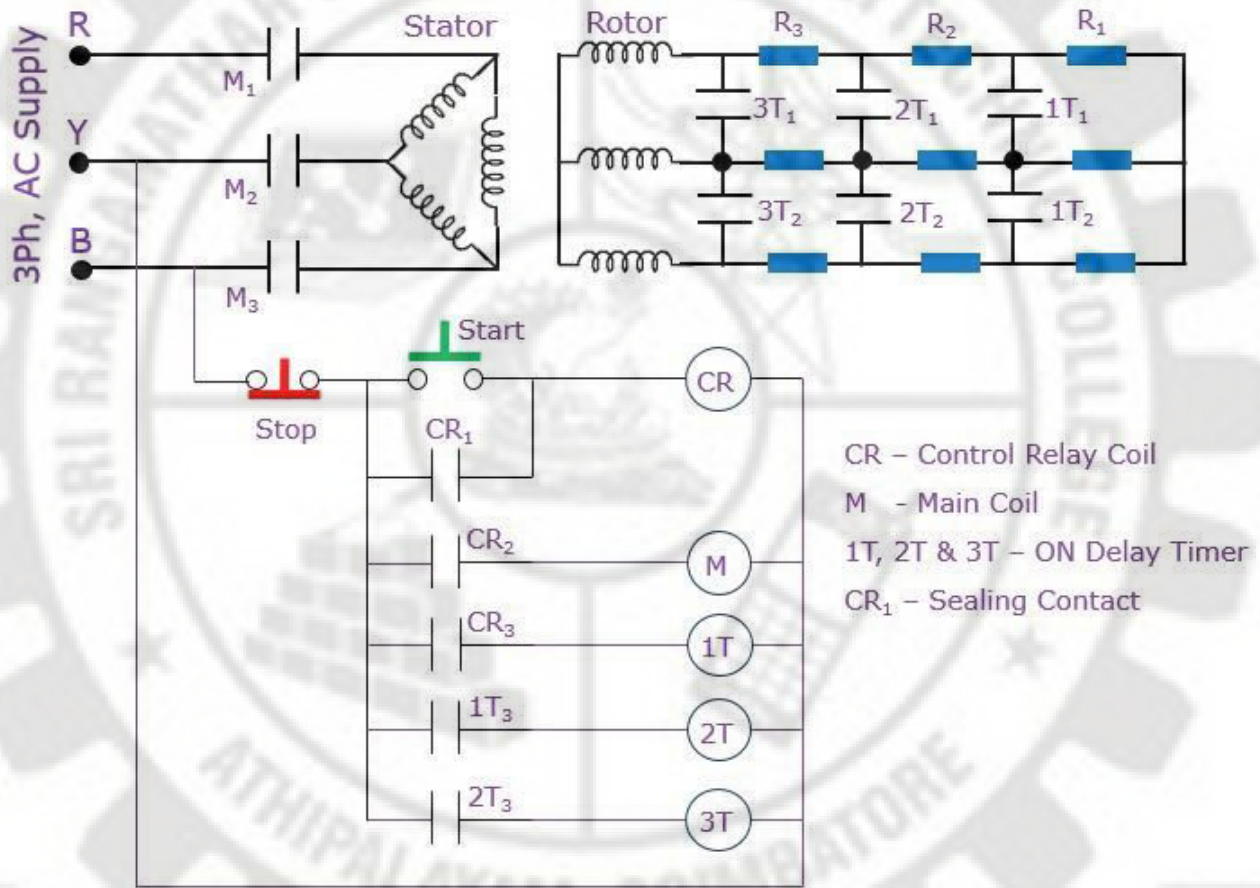

Figure 2.12 Power and Control circuit of Automatic Rotor Resistance Starter

Sequence of operation:

Press START push button and observe the following sequence of operation

1. Control relay CR is energized & retained through its sealing contact CR₁.
2. CR₂ & CR₃ closes and energises the main coil M and ON delay Timer T₁.
3. Main contacts M₁, M₂ & M₃ gets closed.
4. Motor gets 3 phase supply and runs with external rotor resistance.
5. After preset time delay, contact T₁ closes so that resistance R₁ is short circuited and ON delay timer T₂ is energised.
6. After preset time delay, contact T₂ closes so that resistance R₂ is short circuited and ON delay timer T₃ is energised.
7. After preset time delay, contact T₃ closes so that resistance R₃ is short circuited.
8. Slip ring induction motor continues to run as squirrel cage motor.
9. To stop the motor press, STOP push button.

Secondary frequency acceleration starter:

Frequency of rotor induced emf, f_r at any speed is a function of slip s , of the motor and is expressed as:

$$f_r = sf$$

If line frequency is 50 Hz. then frequency of rotor voltage at a slip of 0.02 is, $f_r = 0.02 \times 50 = 1$ Hz. Frequency responsive relays 1F, 2F, 3F as shown in Fig. are connected in the secondary circuit.

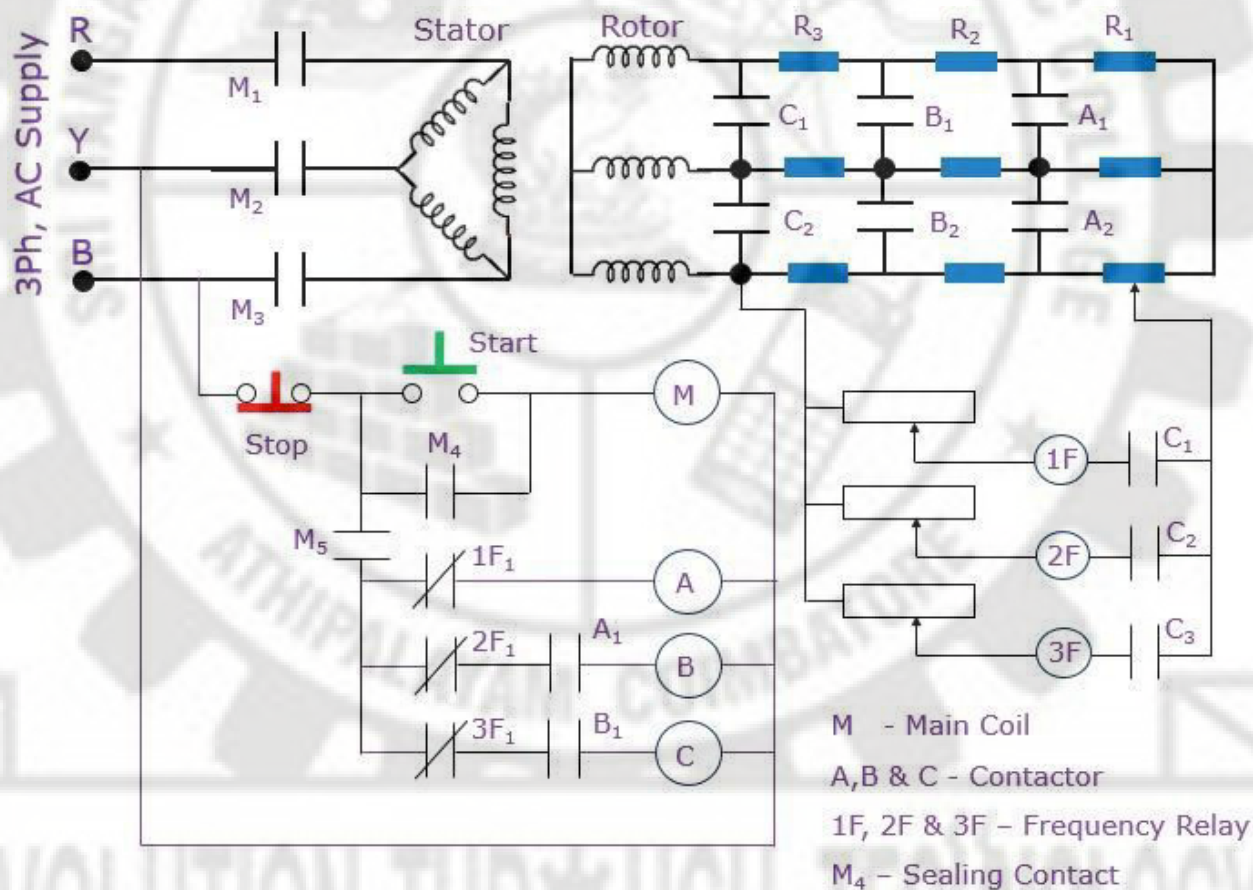

Figure 2.13 Power and Control circuit of Secondary frequency acceleration starter

Sequence of operation:

1. When the START-push button is pressed, the contactor M energizes the stator and motor starts with full resistance in rotor circuit.
2. At starting, relay 1F will pick up as its resonant frequency is 50 Hz. Its contact 1F₁ opens. As the motor accelerates the rotor frequency drops.
3. When the frequency falls to 45 Hz, the relay 1F drops, its contact 1F₁ closes and energizes contactor A.
4. Energisation of contactor A cuts off one set of resistance from rotor circuit and the motor accelerates further. As the motor gains speed its rotor frequency falls.

5. At 30 Hz the relay 2F drops and relay 3F picks up. As relay 2F drops its contact $2F_1$ closes and energizes contactor B which shorts another set of resistance. At the same time relay 3F picks up at 30 Hz and its (NC) contact $3F_1$ opens.
6. The motor further gains speed and its frequency decreases to 15 Hz. At this frequency relay 3F drops. Its NC contact $3F_1$ closes and energizes contactor C through already closed contact B_1 .
7. Energisation of contactor C cuts off all the resistance from the rotor circuit and the motor accelerates to its final speed.

UNIT – II AC MOTOR CONTROL CIRCUITS

MODEL QUESTIONS

Two Mark Questions:

1. How will you connect retaining contact in DOL starter?
2. Draw the current speed characteristics of AC motor during acceleration.
3. What is the function of autotransformer in autotransformer starter?
4. What is open circuit transition in autotransformer starter?
5. What is closed circuit transition in autotransformer starter?
6. State whether surge current is available or not in the closed circuit transition.
7. Why the autotransformer starters are rarely used?
8. List the types of star delta starter.
9. Name the type of timer used in automatic star delta starter.
10. What is the function of interlock contact in star delta operation?
11. What do you mean by toggle time in star delta starter?
12. How many leads are to be brought out from the motor while using star delta starter?
13. How will you reverse the direction of rotation of 3 phase induction motor?
14. How will you identify the main contacts in a contactor?
15. How many speeds are possible in pole changing motor?
16. Which braking causes less heat generation?
17. How is dynamic braking effected in induction motor?
18. What is the usual method of wound rotor connection?
19. State whether wound rotor is connected in star or delta.
20. List any two applications of rotor resistance method of starting in slip ring induction motor.
21. What will be the rotor frequency at the time of starting slip ring induction motor?
22. Which motor is started by using secondary frequency acceleration starter?

Three Mark Questions:

1. Draw the circuit diagram of DOLstarter.
2. Write a note on electric braking.
3. Write a note on open circuit transition in star-deltastarter.
4. Compare a automatic and semi automatic star deltastarter.
5. What is the need of sealing contact? Explain.
6. Write a note on interlockcontact.
7. Write a note on sequential interlockcontact.
8. Write a note on closed circuit transition in autotransformerstarter.
9. What are the methods of starting cage inductionmotor?
10. How do you reverse the direction of inductionmotor?
11. What are the electricalbraking methods recommended for inductionmotor?
12. What do you mean by dynamic braking in cage inductionmotor?
13. What do you mean by two speed controller of cage induction motor? Where is it used?
14. List the applications of slip ring inductionmotor.

Ten Mark Questions:

1. Explain the control circuit and main circuit of DOLstarter.
2. Explain the control circuit and power circuit of autotransformerstarter.
3. Draw and explain the control circuit and main circuit of auto transformer open circuit transition starting of cage inductionmotor.
4. Draw the control circuit for autotransformer starter of closed circuit transition and explain.
5. Draw and explain the control circuit and main circuit of semi -automatic star-deltastarter.
6. Draw and explain the control circuit and main circuit of automatic star deltastarter.
7. Draw and explain the control circuit of two speed control in induction motor.
8. Explain the control circuit for reversing the direction of three phase inductionmotor.
9. Explain the control circuit and main circuit for dynamic braking of cage inductionmotor.
10. Explain the control circuit for automatic rotor resistance starter for three phase slip ring inductionmotor.
11. Explain the control circuit for the operation of secondary frequency acceleration starter.

UNIT : 3 INDUSTRIAL CONTROL CIRCUITS

OBJECTIVES:

After studying this chapter, the student will be able to:

- Explain the industrial control circuit of planer machine, skip hoist, water pump, electric over, air compressor, over head crane conveyor system and Elevators.
- Explain the trouble spots in the control circuit.
- Discuss the general procedure for troubleshooting.

Planner machine control:

Planer machines (also called a shaper) is used for shaping a job/work piece to required dimensions by a cutting tool. The to and fro movement of the bed is achieved by forward and reverse rotation of the motor. Rotational motion of the motor is converted into longitudinal motion with the help of rack and pinion arrangement. Rotational motion of the motor is transmitted to the load with the help of an electrically operated clutch. When the dc coil of this clutch is energised the motor pulley gets coupled to the bed side pulley. When the coil is de-energised the motor pulley gets decoupled from the bed side pulley and the bed comes to standstill quickly. The clutch coil is energised along with the motor irrespective of whether the motor is to run in forward direction or in reverse direction. The limit of forward and reverse movement of the bed is determined by the positions of two limit switches as shown in Figure 3.1.

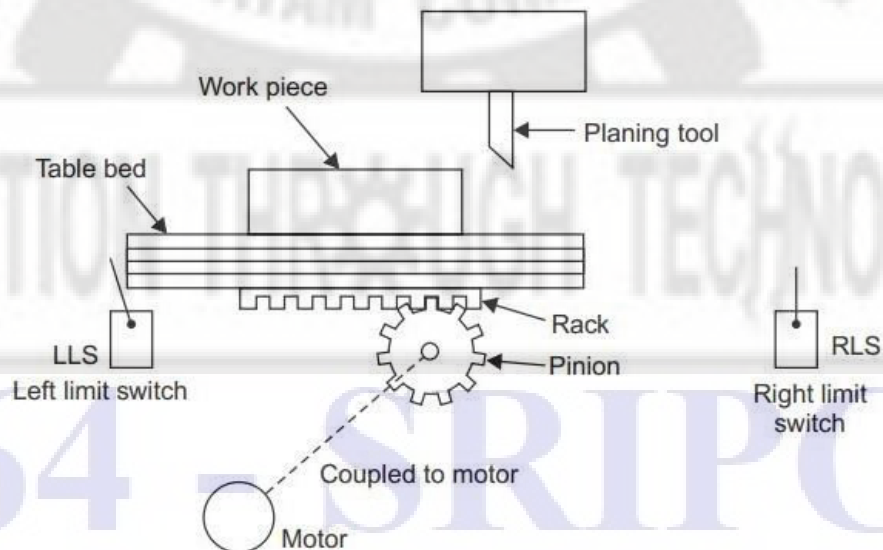

Figure 3.1 Planner machine arrangement

The power circuit of the motor includes simple connections for forward reverse operation of the motor.

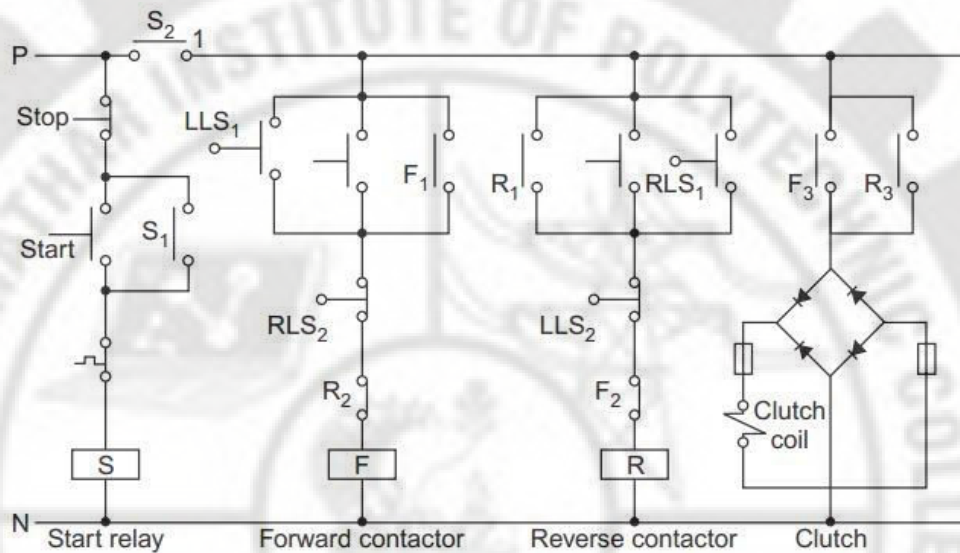

Figure 3.2 Control circuit of Planner machine

Sequence of operation:

- i) When the bed is at extreme left position:
 - LLS (Left Limit Switch) is actuated
 - NO contact LLS₁ will be closed
 - NC contact LLS₂ will be open
 - RLS (Right Limit Switch) will be in unactuated condition
 - NO contact RLS₁ being open
 - NC Contact RLS₂ being closed
- ii) When the START-push button is pressed starting relay S gets energised and closes its NO contacts S₁ and S₂. Sealing effect is provided by S₁.
- iii) Forward contactor F is energised through closed contact LLS₁ and NC contacts RLS₂ and R₂. Energised F contactor closes its NO contact F₁ & F₃ and opens its NC contact F₂ and also runs the motor in the forward direction. Contactor F will now get hold through F₁.
- iv) The clutch coil will get energised through Contact F₃. DC current is fed to the coil by a rectifier bridge to have a strong magnetic action.
- v) When the bed reaches extreme right position, limit switch RLS is actuated, its contact RLS₁ closes while RLS₂ opens and causes de-energisation of contactor F and thus supply to the motor is cut off and the clutch is also disengaged. The bed comes to stop quickly.
- vi) Contactor R will get energised through closed contact RLS₁ and NC LLS₂ and F₂, and will be held through its own contact R₁. Its contact R₃ will energise the clutch coil. Closing of contactor R will therefore cause movement of the bed towards the left till left side limits LLS is actuated.

- vii) When the limit switch LLS is actuated contactor R will get de-energised due to opening of contact LLS_2 while contactor F again will get energised through closed contact LLS_1 and normally closed contact RLS_2 and R_2 .
- viii) Thus it is seen that after completing one cycle of movement, the bed again starts automatically for the second cycle.
- ix) STOP-push button is pressed to de-energise the start relay.
- x) If the bed stops in between due to power failure, the machine would not start in Auto mode and press the respective Reverse or Forward pushbuttons.

Skip hoist control:

Skip hoist is used in industry for shifting material from floor level to some higher altitude. Skip hoist consists of a trolley which moves on rails on an inclined plane. On reaching the top of the incline the trolley tilts and drops the material into a large container called silos. The material from silos is then utilised as per requirement.

The movement of trolley in the skip hoist is governed by a 3 phase induction motor. This induction motor is controlled by two contactors U and D. The power diagram is similar to Forward/Reverse starter. When contactor U is energised the motor runs in forward direction and the trolley is pulled up the incline. When contactor D is energised the motor runs in reverse direction and the trolley moves down in the incline. The motor is stopped quickly by an electromagnetic brake which is not shown in the figure.

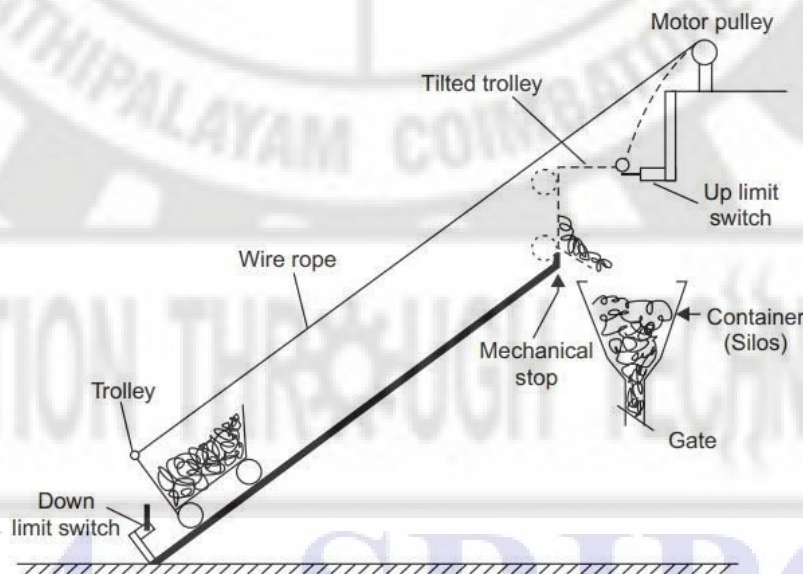

Figure 3.3 Schematic representation of a skip hoist

- i) When the START-UP button is pressed, contactor U gets energised through NC closed contact D_2 and LSU_1 and runs the motor in forward direction.
- ii) The motor stops when UP limit switch LSU is actuated and its NC contact LSU_1 opens and de-energises contactor U. At the same time normally open contact LSU_2 closes and energises time delay relay T.

- iii) The motor remains off and the trolley stays tilted for a period, as set on the time delay relay T. This delay is provided so as to allow all the material in the trolley fall into the silos. When the Time delay relay operates, its contact T_1 closes and energises contactor D through normally closed contact U_2 and normally closed contact LSD_1 .

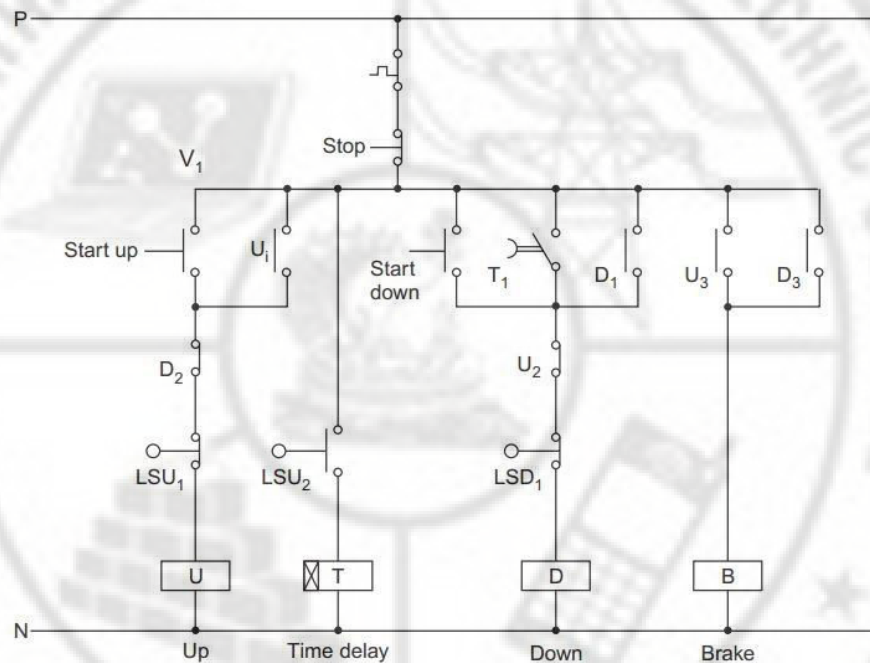

Figure 3.4 Control circuit for a skip hoist

- iv) As the contactor D closes, motor runs in the reverse direction and the trolley starts moving in downward direction.
- v) When the trolley reaches the down position, limit switch LSD is actuated and thus its normally closed contact LSD_1 opens and de-energises contactor D.
- vi) For the next cycle of hoist, the START UP push button is pressed when the trolley has been filled with material to be taken up.
- vii) For manual operation of the downward motion, the START-DOWN push button can be pressed. This push button is necessary for bringing the trolley to down position in case of power interruption during the downward motion of the hoist.
- viii) The brake coils of the motor are controlled by contactor B. The brake opens when brake coils are energised. Contactor B is energised by the normally open contacts U_3 and D_3 . The brake remains engaged when both the contactors are in de-energised condition.

Automatic control of a water pump:

The water pump which pumps water from a storage tank into a pressure tank. The pump is allowed to run until the tank is full up to a certain level. Float switch FS_1 will actuate when water of the tank would reach its upper most level H. Under such limiting position the float switch will stop the pump. Float switch FS_2 would sense the lowest level (L) of water in the tank.

When this float switch actuates, it would start the pump to raise the water level upto the upper limit. The physical arrangement of the pump and the two tanks along with the control components are shown in Figure 3.5.

To let pressurised air enter the tank above the water level, a solenoid valve has been provided. When the coil is energised the valve opens and air enters the tank. When sufficient pressure is built up inside the tank, pressure switch PS_1 actuates and supply to solenoid valve is cut off. Float switch FS_3 in the storage tank has been provided to sense a very low level of water. If the water level in the storage tank would reach a very low level the switch would put off the pump.

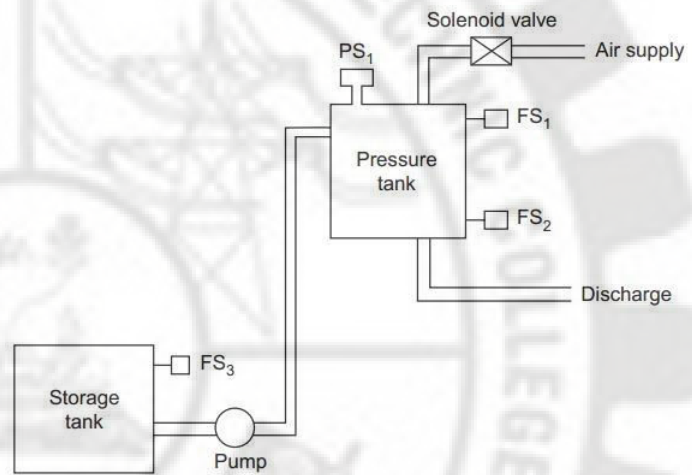

Figure 3.5 Schematic arrangement of overhead pressure tank

Manual Operation:

The pump is run on manual mode when there is some fault in the circuit for automatic operation. To run the pump in manual mode, the selector switch is put on manual position 'M' and line 1 is energised. Contactor M of the pump motor gets energised and is held through its own contact M_1 when the START-push button is pressed. The operator has to watch and see that when the tank is nearly full, the pump is stopped by pressing the STOP pushbutton.

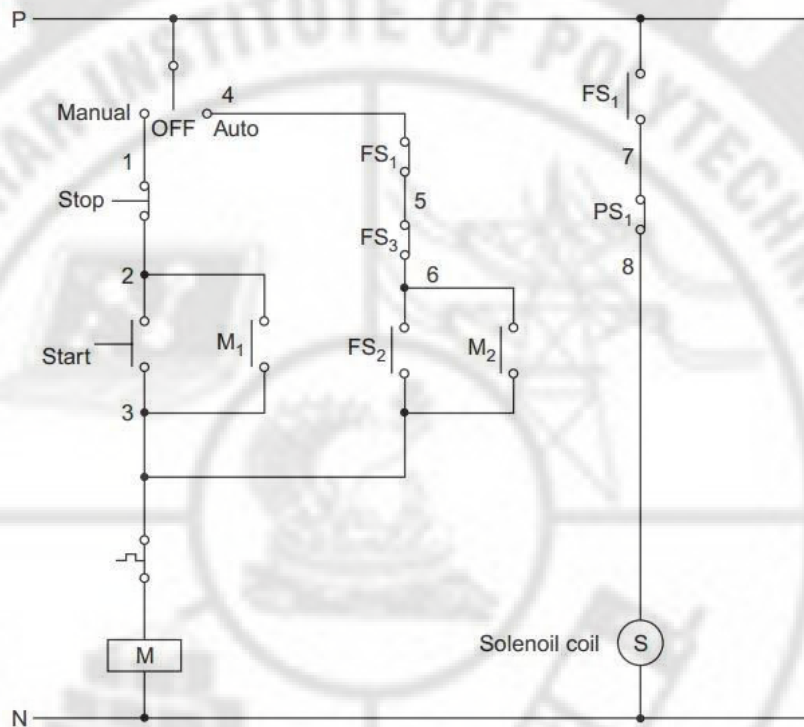

Figure 3.6 Control circuit for a pressurized overhead tank

Auto Operation:

For automatic operation of the pump, the selector switch is put on Auto mode. On Auto mode of the selector switch, control supply reaches line 6 through normally closed contacts FS_1 and FS_3 .

- i) When the water level falls below the lowest level (L) in pressure tank, FS_2 is actuated and contactor M gets energized. Sealing effect is provided by normally open contact M_2 .
- ii) Float switch FS_2 then loses control and the pump continues to run even when water rises above the lower limit (L).
- iii) When the upper limit float switch FS_1 is actuated and its normally closed NC contact opens to disconnect supply at line 5, contactor M will get de-energised and the pump would stop.
- iv) Contactor M is also de-energised if FS_3 actuates and opens its normally closed, NC contact when water level in the storage tank goes below the lowest level.
- v) From the circuit it is seen that the coil of the solenoid valve is energised when the normally closed contact PS_1 of the pressure switch is closed.
- vi) Another condition for allowing the air to enter the tank is that water level should be above the upper level limit set by float switch FS_1 .
- vii) When the water level will fall below this level, FS_1 will open and air supply will be cut off. When the pressure of air inside the tank increases above the setting, contact PS_1 opens to de-energise the solenoid S.

Control of Electric Oven:

Electrically heated ovens are used for a wide variety of purpose in industry, e.g., in heat treatment of metals like annealing and hardening, stoving of enameled wire, drying and baking of cores in foundry, drying and baking of pottery etc. Ovens using wire resistance heating elements can be made to produce temperatures upto 1000°C. Temperatures upto 3000°C can be obtained by using graphite elements.

Temperature control in ovens is obtained by changing current through the heating elements. Current through the heating elements is changed by connecting them in different fashion.

Some methods of control of current through the resistance elements are as follows:

- a) Using variable number of resistance elements:

This method tends to give uneven temperature in the oven if the elements not in use are not evenly distributed over the oven surface. Even distribution of such elements, however, leads to complicated wiring.

- b) Series parallel and star-delta connection of heater elements:

This is the simplest and most widely used method of control of current. When this method is used in combination with the method mentioned in (i) above, sufficient variations in temperature is obtained for most practical purposes.

Series parallel connection of heating elements:

Series-parallel connection of heaters in 3 phase system is shown in Figure 3.7. As in the control diagram of Fig. 3.7 (a), when the control relay CR is ON, through a selector switch either contactor A or contactors B and C can be energised. When the selector switch is set for low heat, contactor A is energised through closed contact of thermostat (temperature controller). Contactor A when energised connects the two heater elements in each phase in series. The line voltage thus gets divided across the two elements. When the selector switch is put on high heat contactor A is de-energised and contactors B and C are energised. Referring to power diagram it can be seen that closing of contactors B and C results in the two heater elements of each phase getting connected in parallel across full line voltage.

764 - SRIPC

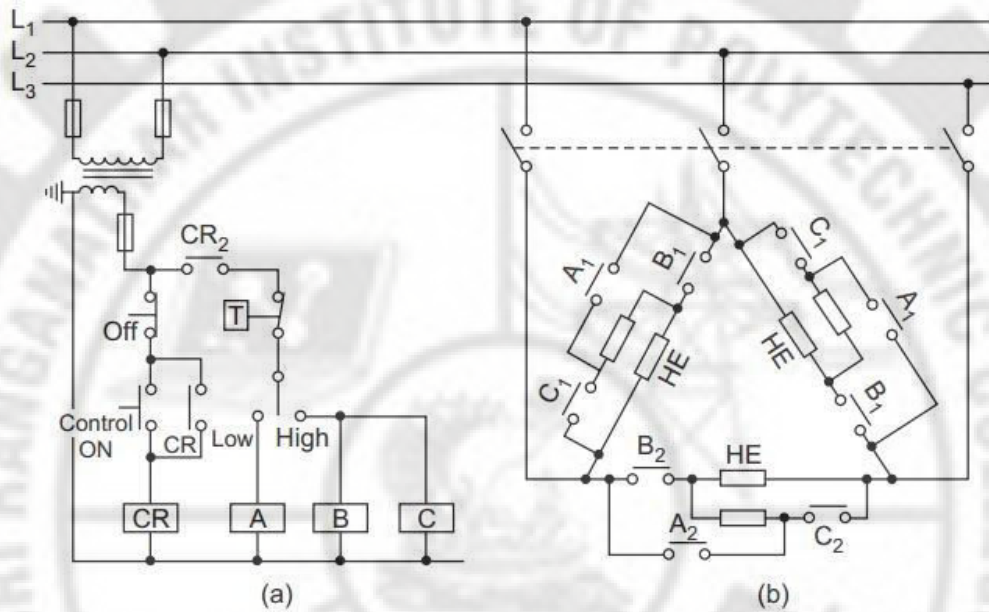

Figure 3.7 Series parallel connection of heaters in a 3-phase system
(a) Control circuit (b) Power circuit

When the selector switch is on high heat, the thermostat setting should also be made at the required higher temperature. Thermostat will control the temperature within a certain range depending upon the differential setting.

Star-delta connection of heating elements:

Figure 3.8 shows a three phase connection where the full line voltage gets applied across each heating element connected in delta when contactor B closes. Heater elements can be switched over into star connection if instead of contactor B, contactor A gets closed. In star connection the voltage across a heater element will be $V/\sqrt{3}$ times the voltage in delta connection, V being the line voltage. Thus in star connection the heat will be 33% of that in delta connection.

764 - SRIPC

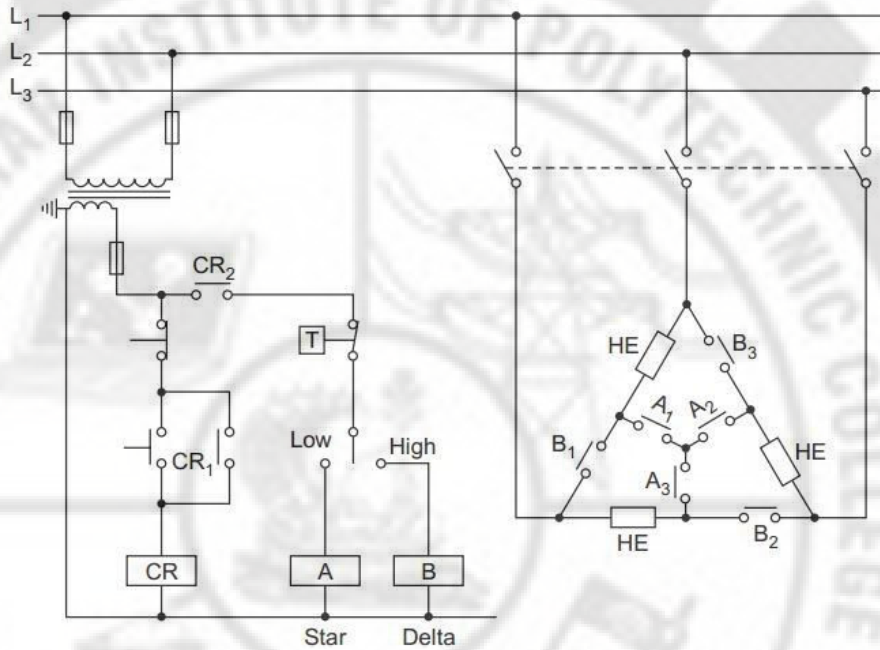

Figure 3.8 Star-delta connection of heating elements

A selector switch is to be used to energise contactor A when low heat is required, and contactor B when high heat is required. The thermostat contact connected in series with the selector switch has been used to get automatic switching off of contactors so as to maintain the required temperature.

Over HeadCrane:

Overhead cranes are used for shifting heavy weights within a limited area. The area is decided by the span of 'long travel motion' and 'cross travel motion' of the crane. An over head requiring high starting torques in all the motions. This necessitates the use of slip ring induction motors.

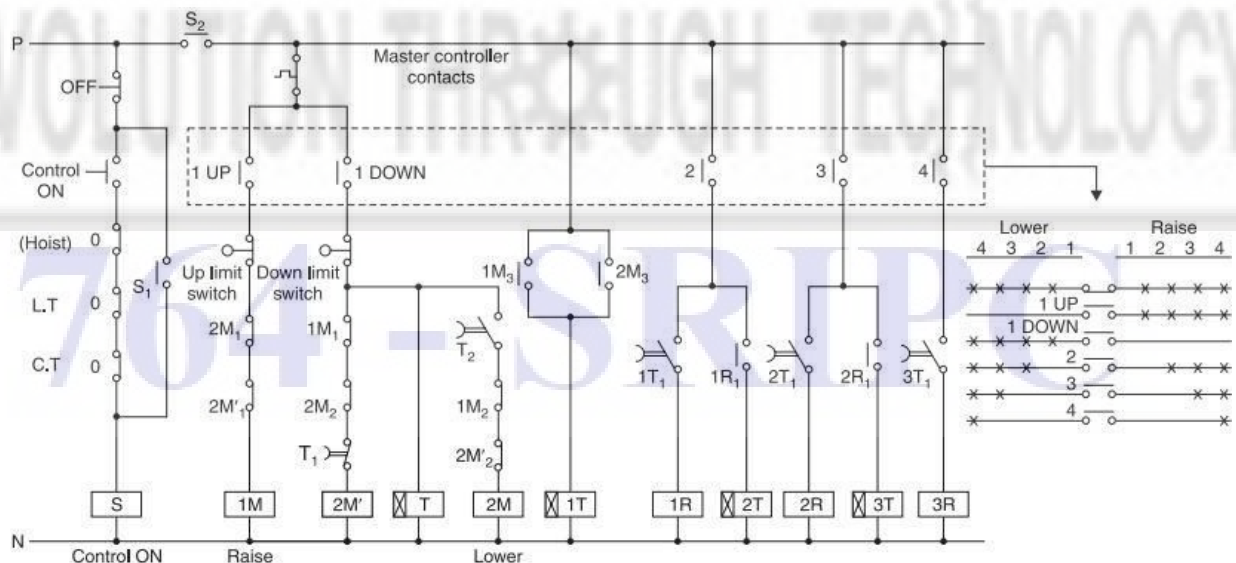

Figure 3.9 Control circuit for an Overhead Crane

In the control circuit start relay S gets energised and remains held only when the '0' contacts of all the three Master controllers (Hoist, LT and CT) are in closed position i.e., levers are in neutral or OFF position. Energisation of relay S activates the control circuit through contact S_2 .

- i) On moving the controller handle to position 1 on the right for raise operation, contact 1UP closes. Closing of this contact energises contactor 1M provided the up limit switch contact is closed. When contactor 1M closes the motor starts to raise the weight up at slow speed as all the resistances R_1 , R_2 and R_3 are connected in the rotor circuit.
- ii) When 1M is energised, its auxiliary contact $1M_3$ closes and energises timer 1T. After the pre-set time, 1T operates and its delayed contact $1T_1$ closes in the coil circuit for resistance contactor 1R. Contactor 1R however gets energised when the controller is brought to position 2, towards right i.e., when the controller contact 2 closes. Energisation of 1R cuts off one set of resistance R_1 from the rotor circuit and therefore the motor accelerates to a higher speed.
- iii) Auxiliary contact $1M_1$ and $1M_2$ also opens when contactor 1M gets energised. They provide interlocking so as to avoid simultaneous operation of lower motion contactors 2M and 2M'.
- iv) Energisation of contactor 1R, also leads to energisation of timer, 2T through the auxiliary contact $1R_1$.
- v) When timer 2T operates, its contact $2T_1$ would close but contactor 2R will get energised only when the controller is brought to position 3. Energisation of 2R cuts off another set of resistance R_2 from the rotor circuit and therefore the motor accelerates to third higher speed.
- vi) Energisation of contactor 2R also leads to energisation of timer 3T through the auxiliary contact $2R_1$.
- vii) When timer 3T operates and the lever of the controller is brought to position 4, the resistance contactor 3R gets energised which accelerates the motor to the final speed by cutting off the last step or resistance R_3 from the motor circuit.
- viii) It may be understood that the timer contacts are used in series with the controller contacts to avoid the possibility of bringing the motor to a higher speed directly. Even if the operator moves the handle directly from OFF-position to fourth position the motor will accelerate to fourth speed in steps because timer 1T, 2T, and 3T will provide delays in energisation of contactor 1R, 2R and 3R.

- ix) To prevent over hoisting of the motor, an UP-limit switch is provided which deenergises contactor 1M. The DOWN-limit switch would de-energise contactor 2M when the lower limit is reached.
- x) For downward motion i.e., for lowering, when the lever of the master controller is moved towards the left side position 1, contact 1 DOWN is actuated which energises contactor 2M' through normally closed contact of the DOWN-limit switch. This contactor connects only two phase supply to the motor. Thus due to single phasing effect less torque is developed by the motor and the brake also does not release fully.
- xi) A timer T also gets energised in parallel with contactor 2M'. When the timer T operates after a few seconds its contact T₁ opens and de-energises contactor 2M', whereas contact T₂ closes to energise contactor 2M. Energisation of contactor 2M supplies three phase power to the motor for lowering operation. This single phasing of motor during starting of lowering operation, prevents a sudden jerk on the rope due to the weight hanging on the hook.
- xii) The auxiliary contact 2M₃ of contractor 2M starts cutting off the resistance in the same sequence as in the case of raising operation.

Control of air compressor:

Air compressor is an equipment which one will find in almost all industries. An air compressor is used to build up air pressure in a big reservoir for use in the plant. Air pressure in an industry may be used for various purposes like for cleaning operations, as drive for pressure operated machines, in L.P.G. burning, in circuit breaker operation, etc.

A compressor basically consists of a cylinder piston assembly in which reciprocating motion of the piston is used for building up air pressure. An electrical motor is used as drive for the compressor. The air in the cylinder is compressed by the piston movement and is forced into the reservoir.

Sequence of Operation:

- i) When ON push button is pressed, the water pump is switched on and circulate the cooling water. The flow switch will detect the flow of cooling water and close its normally open contact. Closing of this contact will energise relay F due to which its normally open contact F1 will close in the coil circuit of the contactor C.
- ii) The cooling water temperature switch T remains closed as long as the temperature of the outgoing water remains below the high preset temperature. Through this contact a relay T remains energised and hence its contact T₁, which is in the circuit of contactor coil C, remains closed.

- iii) When air pressure in the reservoir is less than the preset high value, the air reservoir pressure switch will remain open and therefore relay 2P will be in the de-energised condition. A Normally open contact $2P_1$ of this relay has been used to energise the unloading solenoid coil.

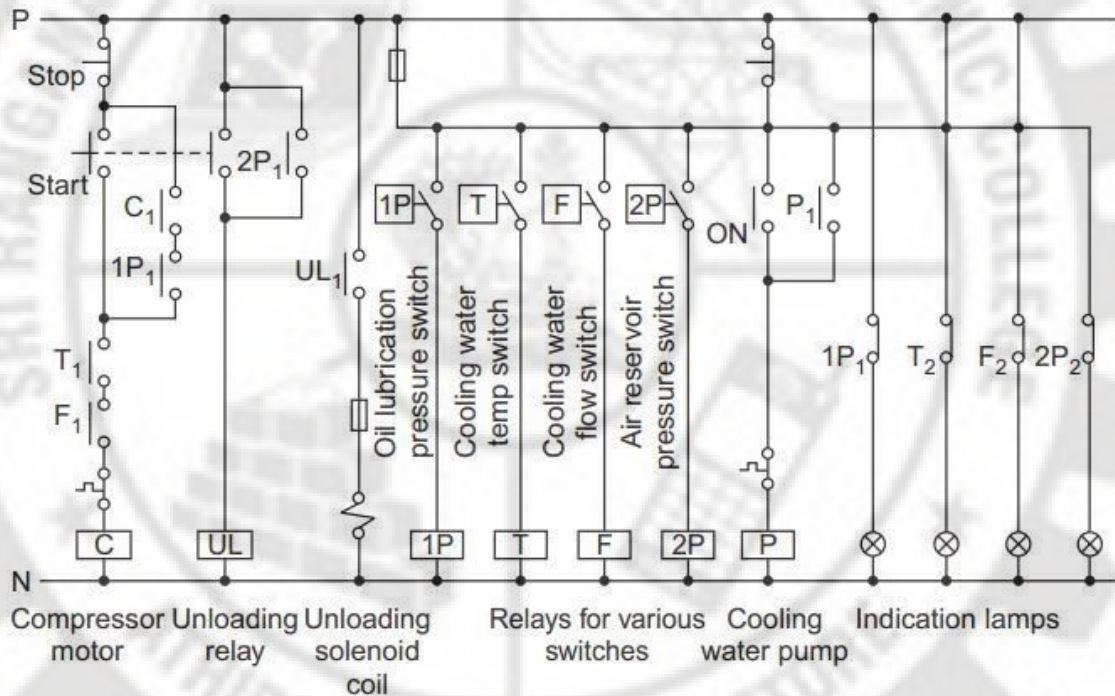

Figure 3.10 Control circuit of Compressor Motor

- iv) When the compressor motor is at standstill having no oil pressure, coil lubricant pressure switch will remain open. Relay 1P will thus be in the de-energised state and its contact $1P_1$ used in the holding circuit of contactor C will remain open.
- v) When START push button is pressed, contactor C gets energised through closed contacts T_1 and F_1 . When the motor picks up speed, oil pump coupled to it will also pick up and oil pressure will build up. When the required pressure gets built up, contact of the oil lubrication pressure switch closes and therefore relay 1P gets energised. Sealing effect is provided by contact $1P_1$ and C_1 .
- vi) When start push button is pressed another relay UL will get energized and its contact UL_1 will close to activate the solenoid coil of the unloading valve to keep the compressor unloaded. When the push button is released, the compressor will get loaded to force air into the reservoir.

- vii) During normal running, due increasing temperature, the temperature switch T will closed and energize the relay T. Now its contact T_1 will open to de-energise contactor C, thus stopping the motor.
- viii) Similarly if cooling water flow stops due to tripping of the water pump, the flow switch F will open and contactor F will get de-energised. Its contact F_1 will open and the motor will stop due to de-energisation of contactor C.
- ix) When air pressure in the reservoir rises to the value set on the reservoir pressure switch, the switch will actuate and contact will close to energise relay UL. Energisation of the relay will energise the solenoid coil of the unloading valve. This would lead to unloading of the compressor. The compressor motor would run unloaded as long as pressure in the reservoir remains above the set value of the pressure switch.
- x) Due to use of air in the plant, when pressure of air would fall below the preset value, the pressure switch will get deactuated and the air will again be compressed and get forced into the reservoir.

Control of Conveyor system:

In large plants, materials are shifted from the place of storage to near the machines for processing, through belt conveyors. Finished products from the machines are also carried away through conveyors. The number of conveyors in a system can be very large depending upon the requirement.

As shown in Fig. 3.11, conveyors 1 and 2 feed material into silos, 1 and 2. Diverters are provided on conveyor 2. When diverter 1 is down, material will fall in silos 1 and when diverter 1 is up and diverter 2 is down material will fall in silos 2. When both the silos are filled, proximity switches provided in silos will actuate and stop conveyors 1 and 2. Finished product from silos can be taken out through gates on to conveyor 2 and taken to packaging machine through conveyors 3, 4 and 5.

764 - SRIPC

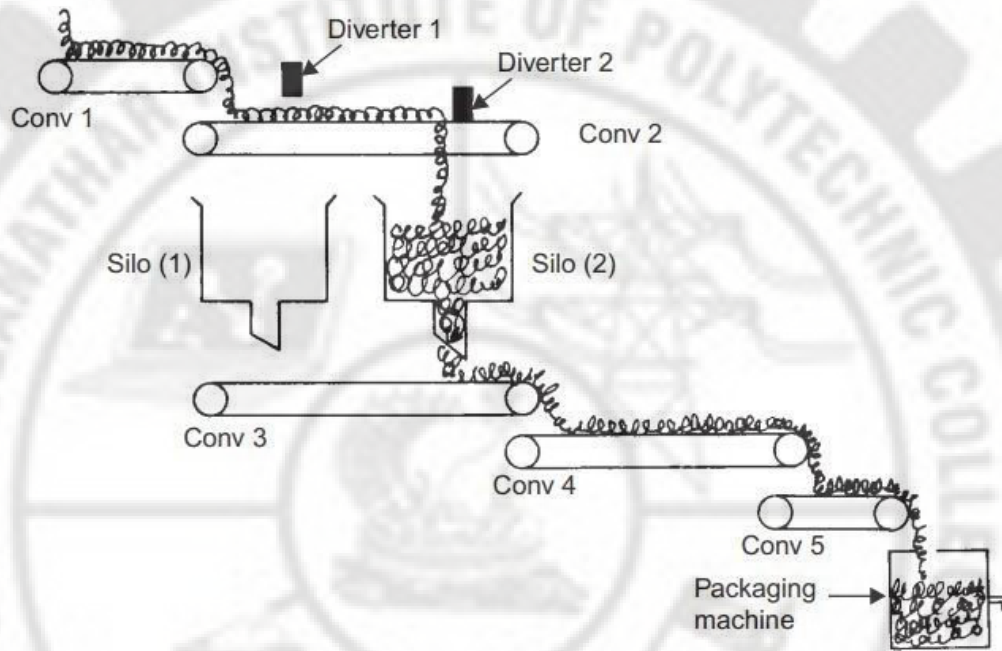

Figure 3.11 Schematic arrangement of Conveyor System

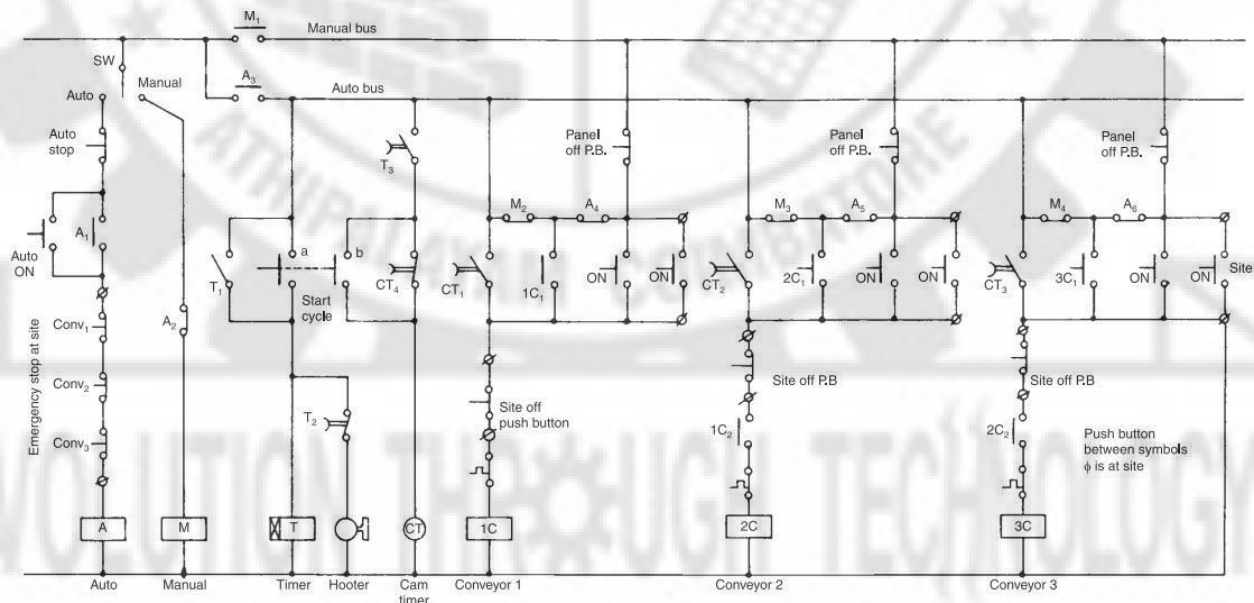

Figure 3.12 Control circuit for a Conveyor System

Sequence of working:

- i) When selector switch is in Auto mode, Auto relay A will get energised on pressing the Auto ON-push button. Due to energisation of relay A, Auto bus is also energized through contact A₃. Contacts A₄, A₅, A₆ will open to isolate manual ON and OFF push buttons.
- ii) When the START cycle push button is pressed, its contacts a and b will close. Closing of contact 'a' will energise timer T and also hooter H through delayed NC contact T₂ of

the timer. When timer operates after preset time, its contact T_2 opens to deenergise the hooter while its contact T_3 will close.

- iii) When contact T_3 of timer closes, cam timer motor CT will get energised if contact 'b' of the START cycle push button is still closed.
- iv) As the motor starts rotating in the direction shown, immediately the contact block CT_4 will deactuate and its contact CT_4 will close i.e., it will come back to its normal position. As soon as this happens, START cycle push button can be released. Now cam timer motor CT will remain energised through its own contact CT_4 till cam 4 rotates through 360° to again actuate contact CT_4 .
- v) When cam timer shaft rotates by 90° from its initial position, contact block CT_1 will be actuated by cam 1 and contact CT_1 will close. Contactor 1C for conveyor 1 will get energised through this contact and will get hold through its own contact $1C_1$.
- vi) When timer shaft rotates by 180° , protruding portion of cam 2 will actuate contact block CT_2 . Its contact will close and energise contactor 2C. When protruding portion of cam 2 moves past the contact, contractor 2C will remain energised rotation its own contact $2C_1$.
- vii) Similarly contactor 3C for conveyor 3 will get energised when after 270° rotation, cam 3 actuates contact block CT_3 .
- viii) When the shaft has rotated by full 360° i.e., when it comes back to its starting point, contact block CT_4 will get actuated to open its normally closed (NC) contact CT_4 . This will de-energise cam timer motor CT and hence the cam timer will stop at this point.
- ix) If auto STOP-push button or Emergency STOP-push button of any conveyor is pressed, all the conveyors will stop immediately due to de-energisation of relay A.
- x) When any site OFF-push button of a conveyor is pressed, then that particular conveyor and the conveyors following it will stop while the conveyor preceding it will continue to run.

Control of Elevator:

Elevators or lifts are used in multistoried buildings for carrying passengers from one floor level to another at a fast speed. There are doors at each floor through which passengers can enter into or come out of the car. The gates may be hand operated or servo motor operated. A lift cannot be operated if any of the hall gates or the car gate is open.

Motors, nowadays being used for lifts are 3 phase induction motors instead of dc motors used earlier. In lifts, a set of electromechanical brakes are provided to stop the car exactly at the floor level.

Control of a lift is obtained through a set of push buttons and limit switches. A set of push buttons enable the operator to take the car to the required floor level. One push button is also provided near each hall gate for calling the lift to that particular floor.

Main annunciation circuits (light indicators, buzzers, bells etc.,) provided in the lift are as follows:

- (1) A light indicator is provided at each floor level to show 'up' or 'down' movement of the car.
- (2) A target annunciation comprises indication showing the floor towards which the car is approaching. This is provided at each floor level and also in the car panel.
- (3) Hall-push button annunciation which comprises indication of floor level at which the lift is required by the passenger along with a buzzer in the car to attract operator's attention.
- (4) A bell provided in the car which rings when the car door is open and the lift is wanted at some other floor by a passenger.

Function of various components:

Sl.No	Name of the device	Function
1	Retiring cam device	It is used to mechanically lock the car at a particular floor. It consists of a coil and a plunger. Normally, when the lift is working, this coil CM remains energised. When the lift remains 30 cms away from desired floor level, the level limit switch actuates and coil CM is de-energised. The 1600 μ F condenser across CM discharges through the coil and makes the plunger drop softly. If a condenser is not provided across the coil, the plunger would drop abruptly and make a lot of noise. A blocking diode does not allow the condenser discharge current to flow back into the rest of the circuit.
2	Hall time switch relay (NT)	Function of this relay is to make the hall push button in-operative when the lift is in motion and also for 5 seconds after its stoppage. If this delay is not there, the lift will not stop at the floor level where the operator desires, but will

		move to another floor level where a waiting passenger has pressed the hall button.
3	Annuciation cut out switch 'ACS'	ACS is used to cut-off the hall buttons permanently.
4	Inspection switch INS	Which makes the Hallpush button in-operative enabling the lift to be operated only through the Car-push buttons.
5	Inspection switch TES	Which allows inspection of the car carriage way. This switch makes both the car and Hall-push buttons in operative. The car can be operated by the person who is inspecting the carriage-way using Up and Down push buttons provided on the top of car.
6	Level sensing limit switches	Which are used to stop the lift at different floors.

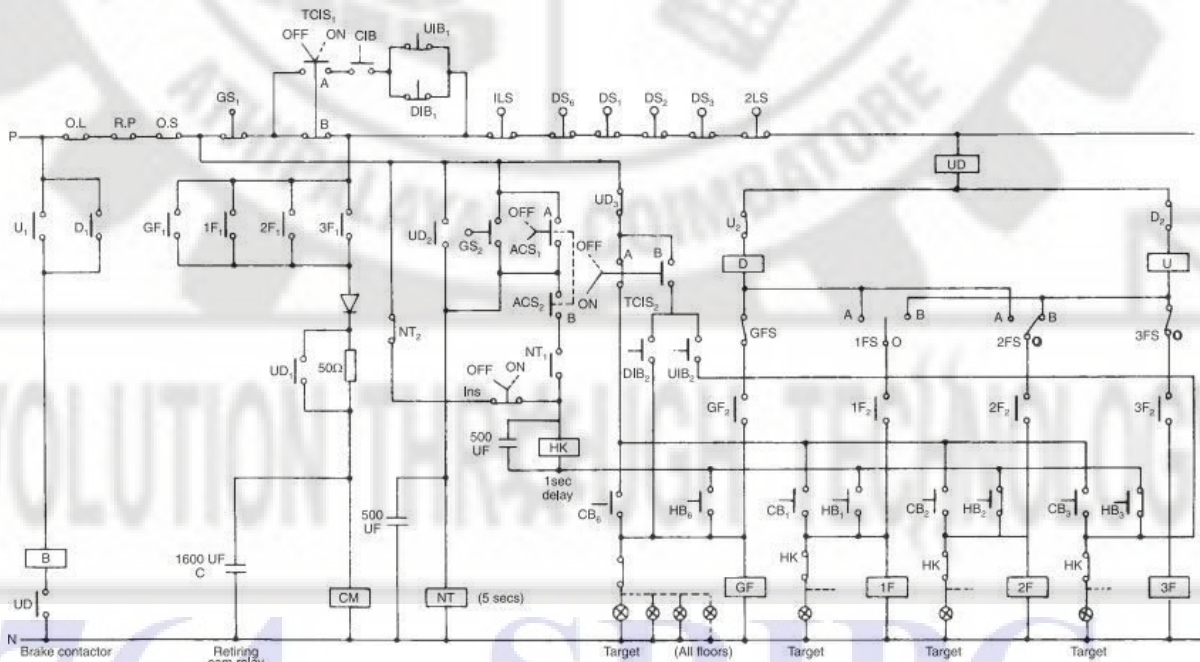

Figure 3.13 Control circuit for a Lift

O.L	Over load	UIB	Up insp button	UD	Main contactor
R.P	Reverse power	DIB	Down insp button	FS	Floor stop switch
O.S	Over speed	ACS	Annunciation cutout switch	LS	Up and down limit switches
GS	Car gate	U	Up contactor	DS	Hoist way gate contacts
CIS	Car inspection switch	D	Down contactor		

Operation of the lift through Car-push buttons:

- i) The lift can be operated in Up or Down motion by pressing car push button CB if control supply reaches the upper coil terminal of contactor U and D. If the contacts (O.L, R.P, O.S, G.S₁, TCIS-1, 1LS, 2LS, DS₁, DS₂, DS₃ and DS₆) connected in series with upper coil terminal of contactor U and D opens the lift will not operate.

Upward Motion:

- ii) The first floor level sensing limit switch 1FS has been shown actuated. Now to move lift to second floor, Car push button CB₂ is to be pressed.
- iii) Control, supply would reach coil of relay 2F through closed contact UD₃, contact A of switch TCIS₂ and push button CB₂. Relay 2F will get energised and its contact 2F₂ will close. This will lead to energisation of contactor U and UD. The circuit will complete through coil of contactor UD, contact D₂, coil of contactor U, contact OB of second floor limit switch 2FS, contact 2F₂ and coil of relay 2F. Thus the lift will move in upward direction. When it would reach second floor, limit switch 2FS will get actuated.
- iv) When the lift leaves the first floor for the second floor, contact position of limit switch 1FS will change. Its contact OA will be closed.
- v) When contactor UD gets energised, supply to car buttons is cut off due to opening of contact UD₃. This means that the car buttons become inoperative, once the lift starts moving.
- vi) If now the lift is moved to the third floor by pressing car button CB₃, contactor U and UD get energised through closed contact of floor limit switch 3FS and coil of relay 3F and its contact 3F₂. The lift stops when 3FS is actuated and 2FS change its position to OA.

Downward Motion:

- i) To bring the lift from third floor to second floor, car button CB₂ will be pressed. This will energise relay 2F and hence its contact 2F₂ will close.

- ii) Down contactor D will get energised as the contact of 2FS is closed in OA position. When the lift reaches second floor, 2FS is again actuated and both contacts OA and OB will be open.
- iii) When the lift is moved further down to first floor, contact position of limit switch 2FS will change and now contact would be made between O and B.
- iv) The lift can be moved from ground floor to the top floor or any other floor directly without stopping at intermediate floors.

Trouble spots in control circuits:

Few areas that contribute to a large percentage of troubles are discussed in the following sections.

Fuses:

Checking the condition of fuses is a good procedure to start when a fault is occurred. Figure shows methods for checking fuses to determine their condition.

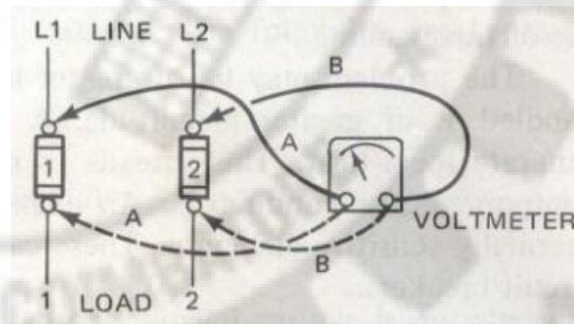

Figure 3.14 Testing of Fuse

Sequence:

S.No	Testing procedure	Result	Condition and Reason
1	Put Lead A on L1 and B on L2	Indicating Line voltage	Input supply is available
		No reading	Problem is in input supply
2	Put Lead A on L1 and B on 2	Indicating Line voltage	Fuse 1 is open
		No reading	<ul style="list-style-type: none"> ▪ Fuse 1 is open ▪ Fuse 2 is open or ▪ Fuse 1 & 2 are open

2	Put Lead A on 1 and B on L2	Indicating Line voltage	Fuse 2 is open
		No reading	▪ Fuse 1 & 2 are open

- A less obvious problem is the type and size of fuse.
- Practice of using copper strip as a temporary replacement may be a problem.
- The policing of fuses may be a problem.

Loose Connections:

Magnitude of Current flow is large in power circuit compared to control circuit. So loose connection in power circuit can generate local heat. This spreads to other parts of the same components.

An example of where direct trouble arises is with thermally sensitive elements. These can be overload relays or thermally operated circuit breakers. Loose connection finally damages the component due to insulation failure. Loose connection in thermally sensitive components may result in malfunctioning. For example, a thermal sensitive overload relay may trip due to conduction of heat to it. The use of stranded conductors in place of solid conductors has in general improved the connection problem.

A regular check for loose connection is the best remedy for avoiding such troubles. Flexible control wires are preferred for wiring a control circuit. These wires are not connected directly in the terminal block or at the relay terminals but are connected after crimping a terminal end on the wire end. For the correction of loose connections, the best advice is to follow a good program of preventive maintenance in which connections are periodically checked and tightened.

Faulty Contacts:

This applies to such components as motor starters, contactors, relays, push buttons and switches. A problem that appears quite often and one of the most difficult to locate is with the NC contact. Observation indicates that the contact is closed but does not reveal if it is conducting current.

Any contact that has had an overload through it should be checked for welding.

Such conditions as weak contact pressure and dirt or an oxide film on the contact will prevent it from conducting. Many times contacts can be cleaned by drawing a piece of rough paper between the contacts.

Caution: Use only a fine abrasive to clean contacts. Do not file contacts. Most contacts have a silver plate over the copper. If this is destroyed by filing, the contacts will have a short life. If contacts are worn or fitted so badly that a fine abrasive will not clean them, it is better to change the contacts.

Another problem that may occur with a double pole, double break contact is cross firing. That is one contact of the double break travels across to the opposite contact, but the other remains in its original position. If both the NO and NC contacts are being used in the circuit, a malfunction of control may occur.

Incorrect wiremarkers:

This problem usually appears on the system integrator assembly floor or in reassembly in the user's plant. One common problem is the transposition of numbers. For example, a conductor may have a 69 marked on one end and a 96 on the other end. Another problem that may occur is in connecting conductors into a terminal block. With a long block and many conductors, it is a common error to connect a conductor either one block above or below the proper position.

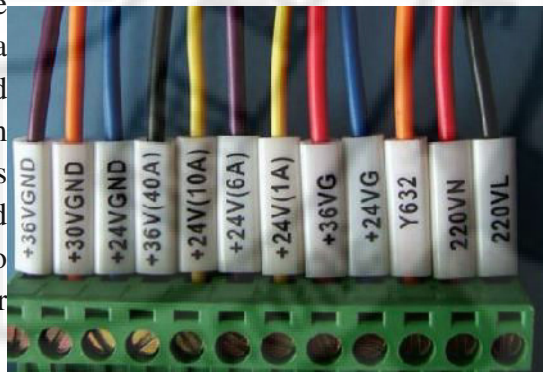

Figure 3.15
Terminal block with Ferules

Combination problems:

Some of the problems in machines cannot be referred to as faults exclusively due to defective electrical or mechanical or hydraulic or pneumatic system. It may be due to the combination of two.

Types and Examples of Combination problems:

S.No	Types	Examples
1	Electrical- Mechanical	Overload tripping of a motor due to: <ul style="list-style-type: none"> ✓ Mechanical overload ✓ Malfunction of OLR

		<ul style="list-style-type: none"> ✓ Defect in the motor itself ✓ heat generated by a loose connection ✓ damaged bearing ✓ two abnormalities at the same time <p>If discrepancy arises in such cases the motor should be decoupled from mechanical load and thorough checking from electrical point of view should be done first.</p>
2	Electrical - Pressure	Solenoid coils burn out: Probably over 90% of all solenoid trouble on valves develops from a faulty mechanical or pressure condition which prevents the solenoid plunger from seating properly, and thus draws excessive current. The result is an overload or a burned out solenoid coil.
3	Electrical - Temperature	<p>Required temperature may not be obtained in ovens and furnaces. Possible reasons are:</p> <ul style="list-style-type: none"> ✓ low voltage damaged heaters and blown fuses ✓ leakage of heat due to use of improper heat insulating material.

Low voltage:

If no immediate indication of trouble is identified, one of the first checks to make is the line and control voltage. Due to inadequate power supply or conductor size, low voltage can be a problem.

A common practice in small shops is to add more machines without proper checking the power supply and the line conductors. The source and line become so heavily loaded and the voltage drops off rapidly. As the voltage drops, the current to a given load increases. This produces heat in the motor starters, relays and solenoids, which not only shortens the life of the components but may cause malfunctioning. This may result in magnetic devices such as starters and relays dropping off the line (opening their contacts) through under voltage or overload protective devices.

Low voltage will result in generation of inadequate heat in ovens. For example, if the voltage is dropped to one half the heating element's rated voltage, the heat output will be reduced to one fourth.

Grounds:

For the best operation of an electrical system, some methods of detecting the presence of grounds should be available. There are two methods, one is with neutral grounded and the other without grounding. Each has its own merits. In the first case one terminal of control supply from

control transformer is grounded. The other terminal of control power supply is protected by a fuse or a miniature circuit breaker. The advantage of this method is that it is easy to check supply at any point, as it is to be done with reference to ground. In this method when a ground fault occurs, the control fuse blows and the machine remains inoperative until the fault is located and removed. Using the grounded method, the circuit is de-energized by the opening of the fuse. This means that the machine will be down until the ground is located and removed. In the small shop this inconvenience is usually not too serious.

Ungrounded Neutral:

In Figure 3.16, the common side is not grounded. A set of two ground detector lamps are connected in series across the power source 1 and 0. A solid ground is then placed between the two lights.

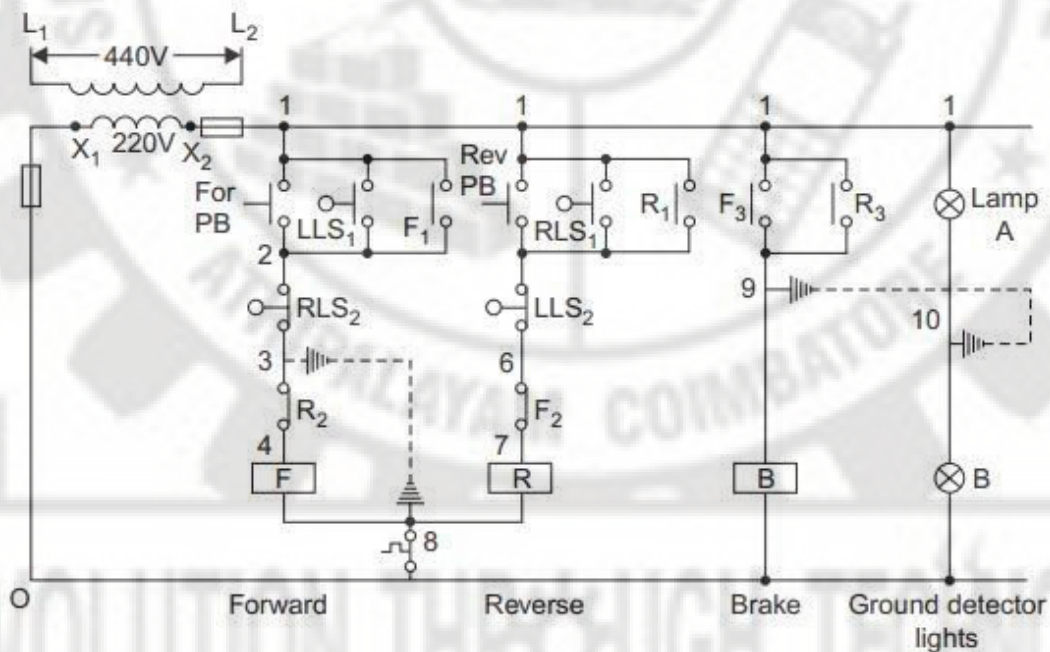

Figure 3.16 Control circuit having ground detector lights

When none of the line 1 and 0 are grounded, both the indication lamps A and B will glow at half brilliance as two 220V bulbs are connected in series. If a ground fault occurs in the system, one of the lamps will go off, while the other one will glow at full brilliance. A bulb getting switched off in a particular side will indicate that control supply of that side has become grounded.

If a ground fault occurs at wire no. 3 and also simultaneously at wire no. 8, control fuses will blow due to short circuiting of the secondary terminals of the control transformer.

The advantage with ungrounded control supply is that even if any point of the control circuit gets grounded, it would not cause immediate trouble. Production can go on without

interruption and ground can be detected and removed on the maintenance day. The important point is that some system should be used to detect the presence of a ground.

Momentary Faults:

Sometimes faults occur but do not persist for a long time. It becomes really difficult to locate the origin of such momentary faults.

The operator of the machine needs to keep a close observation to find out at which part of the cycle of control circuit operation the fault occurs. When the part of the cycle at which the fault occurs is identified, the control circuit pertaining to that portion needs to be checked thoroughly. If the fault occurs at random during the cycle, then those components which are common for the whole cycle operation should be checked.

Loose connection or a broken conductor inside the insulation can also be the cause of momentary fault. Sometimes a control component may be malfunctioning. In case of doubt a component can be replaced by a new one. If the machine is new, fault may already exist in the control circuit due to improper connection.

Poorhousekeeping:

Poor “housekeeping” leads to more work for the trouble shooter. There is an overall economy in having a clean machine and a well-organized and well- executed preventive maintenance program.

Dust, dirt and grease should be removed periodically from electrical parts. Their presence only causes mechanical failure and forms paths between points of different potential, causing a short circuit.

Moving mechanical parts should be checked, particularly in large motor starters. Such items as loose pins and bolts and wearing parts are sources of trouble. When it is necessary to remove a cover or open a door for troubleshooting, immediately replace it after the trouble is corrected.

It is recommended that a regular maintenance schedule should be followed. of each individual machine should be maintained. These records are compiled periodically and are available to the supervisor. This not only leads to faster troubleshooting in the future, but it also gives the supervisor an indication of why the production in a given department may be down.

General procedure for troubleshooting:

Fault: A circuit which has just been wired but is not working as per the design.

1. To analyse the control circuit and ascertain that it has been properly designed as per the control function requirements;
2. To run the machine and follow the operation through the expected sequence until one finds the section of control circuit which is not operating;
3. After locating the faulty section, wiring should be checked. If wiring is as per drawing, then control components of this section should be checked thoroughly;
4. When trouble in the faulty section is located and removed, the machine should be started again to run successfully throughout the complete cycle. In case of fault existing in any other section of the control circuit, one should now try to locate the fault of that section

Fault: Existing circuit which was working properly before the occurrence of a fault.

Troubleshooting procedure:

- a. The first step is to understand the operation and control circuit of the machine.
- b. With the help of the operator, start with the section of the circuit that does not function.
- c. When the faulty circuit section has been identified, first a careful check of the circuit and components involved in that section should be done. A careful visual inspection may help to detect a faulty component or an open wiring. If nothing is found out in the visual inspection, then go to next step.
- d. Find out which operation is not taking place and identify the corresponding contactor/solenoid valve.
- e. Check the voltage across the coil of the contactor/solenoid valve coil. If proper voltage is available across the coil, then check the continuity of coil with ohmmeter.
- f. Working of the contactor or solenoid valve should be checked before replacing the burnt coil. If it is suspected that contactor closing mechanism or solenoid valve is defective, a new contactor or a new solenoid valve should be installed.
- g. Suppose that in the step discussed above voltage is found to be not reaching the contactor coil. In such a case control circuit drawing should be referred, to find out components whose contacts should close to energise the coil.
- h. To find out contact of which particular component is not making, supply should be checked at various points leading to the contactor coil.
- i. If the contact is not making due to a copper oxide film or dirt, cleaning should be done and if contact is not closing properly, adjustment can be done. If, contact is badly pitted it

should be replaced. The other possibility during this checking can be detection of open circuit due to a broken or burnt wire.

- j. Having eliminated the fault, the machine should be started again and if the machine does not operate successfully throughout the complete cycle of operation, the above procedure should again be applied to the next section of the control circuit which is faulty.
- k. Quite frequently, grounding of a wire going from control panel to the machine may be the cause of trouble. A check should be made for detection of ground fault, by putting off the powersupply.
- l. Resistance to ground of the wires should be checked with an ohm meter, or alternatively, a test lamp can be used to detect ground, where 230 V supply with neutral earth is available.

Detection of ground fault using a test lamp:

To check ground, one side of test lamp is connected to phase wire while the other end is connected to the wire which is to be tested for ground. If the wire is grounded the lamp will glow, otherwise it will remain off. This is shown in Fig.

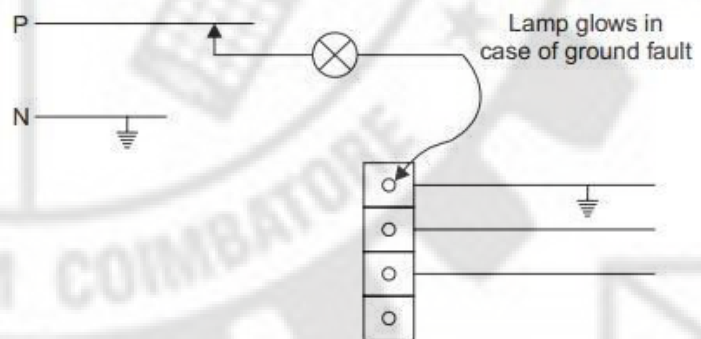

Figure3.17Detectionofgroundfaultusingatestlamp

UNIT – III INDUSTRIAL CONTROL CIRCUITS

MODEL QUESTIONS

Two Mark Questions:

1. What is plannermachine?
2. In a planer machine, what will happen if the right hand side limit switch does notactuate?
3. How does the bed of a planer machine change direction when the bed reaches itsright extreme (or) leftextreme?
4. How will you start the planner machine, if the bed stops in between the limitswitches due to powerfailure?
5. What is the use of clutch in plannermachine?
6. What is the use of skip hoist inindustry?
7. What is need of time delay relay in skip hoistcontrol?
8. List the type of switch or sensor required for automatic control of waterpump?
9. What is the purpose of pressurisedair in an overheadtank?
10. What are the various methods used to control the heat in the electricoven?
11. What are the methods of temperature control in electric oven?
12. List any uses of electrically heated oven in anindustry?
13. What will happen if air reservoir pressure switch in an air compressor fails toactuate?
14. Name the pressure switches used in air compressor controlcircuit.
15. What will happen if the unloading relay does not energisein an aircompressor?
16. Give the uses of pressure switch in air compressor.
17. What is the use of over headcrane?
18. What is the necessity of providing power limit switches in overheadcranes?
19. What is the necessity for single phasing contactor control of overheadcrane?
20. What is the reason to start the conveyor motors in sequencemanner?
21. What is the use ofelevators?
22. What are the push buttons and indicator available in an elevator (lift)control?
23. Draw the various limit switch contact position when the lift car (elevator) is at 3rdfloor.
24. State any four trouble spot in controlcircuit.
25. What problems are caused by loose connection in control and powerconnection?
26. Why should you never file acontact?
27. What is meant by incorrect wire marker in controlcircuit?
28. What conditions lead to a low voltage problem in smallshops?

Three Mark Questions:

1. Draw the schematic diagram of plannermachine.
2. Draw the schematic diagram of skiphoist.
3. Draw the schematic diagram of over head pressure tank.

4. List the industrial applications of Electric Oven.
5. Explain the temperature control in electric oven using series-parallel connection of heater element.
6. Explain the temperature control in electric oven using star-delta connection of heater element.
7. Draw the control circuit of temperature control in electric oven using star-delta connection of heating elements.
8. Briefly discuss about testing of fuses using voltmeter.
9. List the types and example of combination problem as applied to machine control.
10. Discuss the merits and demerits of using a control supply with grounded and ungrounded neutral.
11. Draw a sketch explaining detection of ground fault using a test lamp.

Ten Mark Questions:

1. Explain the mechanical arrangement and control circuit of planer machine.
2. Explain the mechanical arrangement and control circuit of a skip hoist control.
3. Explain the schematic arrangement and control circuit of automatic control of water pump.
4. Draw and explain the control and main circuit of series - parallel connection of heating elements used in electric oven.
5. Draw and explain the control and main circuit of star-delta connection of heating elements used in electric oven.
6. Draw the control circuit of Over head crane and explain its sequence of operation.
7. Draw the control circuit of Compressor Motor and explain its sequence of operation.
8. Draw the control circuit of Conveyor system and explain its sequence of operation.
9. Draw the control circuit of an elevator and explain its sequence of operation.
10. Briefly discuss about different trouble spots in control circuit.
11. Explain with the control circuit how indication lamps are used to denote which of the control line has got grounded in an ungrounded control supply scheme.
12. Briefly discuss about general procedure for trouble shooting in control circuit.

764 - SRIPC

UNIT-4 PROGRAMMABLE LOGIC CONTROLLER

OBJECTIVES:

After studying this chapter, the student will be able to:

- Explain the types of automation.
- Explain the different parts and modes of operation of PLC
- Explain the different types of PLC programming device.
- Compare the hard wired logic and PLC system.
- Explain the criteria for selection of PLC.

Introduction:

The word “Automation” was first used at the Ford motor company in the late 1940. One definition of automation was proposed in 1947 as “the automatic handling of work pieces into, between, and out of machines.

The word ‘Automation’ is derived from Greek words “Auto”(self) and “Matos” (moving). Automation therefore is the mechanism for systems that “move by itself”.

Automation means automatic manufacturing without human control. Automation is a technology concerned with the application of mechanical, electronics and computer based systems to operate and control production.

The objective of automation is to cause the work system to be automatic that is self-acting, self-regulating and self-reliant.

Automation:

Automation is a set of technologies that results in operation of machines and systems without significant human intervention and achieves performance superior to manual operation.

Types of automation:

1. Manufacturing automation:
 - a. Fixed Automation
 - b. Programmable Automation
 - c. Flexible Automation
2. Non-Manufacturing automation:
 - a. Office Automation
 - b. Home Automation
 - c. Building Automation

4.2.1 Manufacturing Automation:

This include fixed automation, programmable automation and flexible automation.

11.2.1.1 Fixed Automation:

Fixed automation refers to the use of special purpose equipment to automate a fixed sequence of processing or assembly operations. This system involves automation and integration of various fixed sequences of operation. It is also known as hard automation. It is used to produce product such as gears, nuts and bolts etc., High specialized equipment, called special purpose machine tools are utilized to produce a product very efficiently and at high production rates.

Advantages:

- i) Maximum efficiency
- ii) Low unit cost
- iii) High production rate

Disadvantages:

- i) Large initial investment
- ii) Inflexible in accommodating product variety.

Applications:

- i) Bottling plants
- ii) Packaging plants

Programmable Automation:

In programmable automation, changes in the sequence of operations is possible by changing the program. The variation in the sequence is achieved by varying the control instructions of the automation system. New programs can be developed and entered to improve the flexibility. Programmable automation is used when the volume of production is relatively low and there are varieties of products to be made. In the Programmable automation products are produced in batches. When one batch is completed, the equipment is reprogrammed to process the next batch.

Advantages:

- i) Flexibility to deal with variation and changes in product
- ii) Low unit cost for large batches
- iii) High production rate

Disadvantages:

- i) New products requires long set up time

Applications:

- i) CNC Lathe

Flexible Automation:

In flexible automation system, different products can be produced on the same equipment in any order or mix. It is also called as Flexible Manufacturing System (FMS). The ability of the system to produce various combination and schedule of products makes this system highly

flexible in accommodating the dynamic needs of an industry. There is no lost production time while reprogramming the system and altering the physical setup.

Advantages:

- i) Minimum production time losses
- ii) Flexibility to deal with products design variations
- iii) Customized products.

Disadvantages:

- i) Large initial investment
- ii) High unit cost compared to fixed and programmable automation

Applications:

- i) Industrial Robots

4.2.2 Non-Manufacturing automation:

This includes office automation and integrated data processing mechanism, automatic elevators, transportation ticket selling equipments etc.,

Office automation:

Office automation refers to the varied computer machinery and software used to digitally create, collect, store, manipulate, and relay office information needed for accomplishing basic tasks. The information may be of many processes and formats—payroll preparation, transportation, reservation, scheduling, banking, security transaction and cost price analysis etc.,. Increased productivity per office worker is indeed a major advantage of office automation. Information required for business management is rapidly managed, integrated and sent long distance through office automation.

Home automation:

Home automation refers to the automatic and electronic control of household features, activity, and appliances. Home automation systems are composed of hardware, communication and electronic interfaces that work to integrate electrical devices with one another. The three main elements of a home security system are sensors, controllers and actuators. Sensors can monitor changes in daylight, temperature or motion detection; home automation systems can then adjust settings to the preferred levels of a user. Controllers refer to the devices—personal computers, tablets or smartphones—used to send and receive messages about the status of automated features in users' homes. Actuators may be light switches, motors or motorized valves that control a mechanism or function of a home automation system.

Building automation:

Building automation is the centralized control of a building's heating, ventilation, air conditioning, lighting, fire fighting, water distribution and parking systems etc.,. It is controlled

by a building management system (BMS) or a building automation system (BAS). These are used in smart buildings. The intelligent system/computers are used to control these systems.

Advantages of automation:

- Increase in productivity
- Reduction in production cost
- Minimization of human fatigue.
- Less floor area required
- Reduced maintenance requirement
- Better working conditions for workers
- Effective control over production process
- Improvement in production quality
- Reduction in accidents
- Uniform components are produced.
- More safety

Disadvantages of automation:

- High capital cost
- Increased unemployment
- Failure of one part may affect others

Systems used for automation:

- a. CAD – Computer Aided Design
- b. CAM – Computer Aided Manufacturing
- c. CAE – Computer Aided Engineering
- d. CIM – Computer Integrated Manufacturing
- e. FMS – Flexible Manufacturing System
- f. PC – Personal Computers
- g. Robots -Robotics
- h. PLC – Programmable Logic Controller
- i. SCADA – Supervisory Control And Data Acquisition
- j. DCS – Distributed Control System
- k. CNC – Computer Numerical Control

PLC Introduction:

The programmable Logic Controller is an assembly of solid state digital logic elements designed to make logical decision and provide control. PLCs are used for the control and operation of manufacturing process equipment and machinery. The PLC is an industrially hardened computer designed to perform control functions in industrial environment. This means that unlike your personnel computer, the PLC must be capable of operating in high temperature with poor power conditions in dusty, dirty, corrosive atmospheres and withstand shock and vibration. In addition, PLCs are designed to be programmed by individuals who are familiar with motor control circuits. There, most PLC program in a language that resembles ladder diagrams, which makes learning PLCs very easy for most electricians. In addition to switching functions, PLCs can also perform counting, calculations, comparison, processing of analog signals and more.

Definition of PLC:

A programmable logic controller is a digital electronic apparatus with a programmable memory for storing instructions to implement specific functions such as logic, sequencing, timing, counting and arithmetic to control machines and processes.

A Historical background of PLC:

- In the late 1960s the American motor car manufacturer General Motors was interested in the application of computers to replace the relay sequencing used in the control of car plants.
- The Hydramatic Division of the General Motors Corporation specified the design criteria for the first programmable controller in 1968. Their primary goal was to eliminate the high costs associated with inflexible, relay controlled systems.
- The first PLC was invented in 1969 by Richard Dick E. Morley, who was the founder of the Modicon Corporation.
- The specifications required a solid-state system with computer flexibility able to:
 - i) Survive in an industrial environment
 - ii) Be easily programmed and maintained by plant engineers and technicians
 - iii) Be reusable

Block diagram of PLC:

PLC consists of three basic sections:

1. Central processing unit
2. Input/output Modules
3. Programming Device

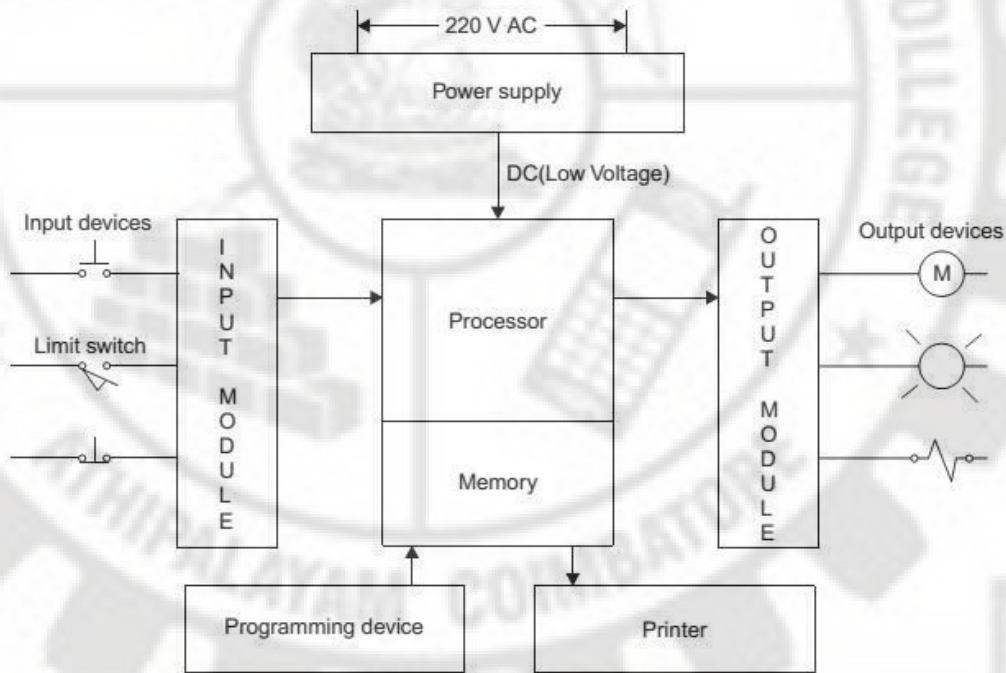

Figure 4.1 Block Diagram of a PLC

1. CPU:

The Central Processing Unit (CPU) Module is the brain of the PLC. The Primary functions are to read inputs, execute the control program, and update outputs.

The CPU consists of following three components:

- i) Processor
- ii) Memory system
- iii) Power supply

i) Processor:

The processor executes the user program stored in the memory system in the form of ladder diagrams. The processor accepts input data from various sensing devices, executes the stored program from memory and sends appropriate output commands to control devices. It can also perform arithmetic functions, data manipulation and communication between the local I/O, remotely located I/O and other networked PLC.

ii) *Memory system:*

The memory system is the area in the CPU where all the *programs*, are stored and executed by the processor to provide the desired control of field devices.

iii) *Power supply:*

Power supply is necessary to convert 120V or 240V a.c into the low voltage d.c (+5V & -5V) required for processor and internal power required for the I/O modules. This power supply unit does not supply power for the actual input or output devices. This can be built into the PLC or be an external unit. Common voltage levels required by the PLC are 24Vdc, 120Vac, 220Vac etc.,

2. *Input/output Section:*

Input modules:

- It senses the presence or absence of an input signal at each of its input terminals.
- It accepts signal from the machine or process and convert them into signals that can be used by the controller.
- The input module provides isolation between the input signal and the PLC.
- The status of input signals are stored in the input image table.

Output Modules:

- It receives the signal from the CPU.
- It converts the controller signals into external signals used to control the machine or process.
- It switches ON or OFF the outputs.
- It provides isolation between CPU and output stage.
- The status of output signals are stored in the output image table.

3. *Programming device:*

The programming unit allows the engineer or technician to enter and edit the program to be executed. The programming device must be connected through cable to the controller when entering or monitoring the control program.

Principle of Operation:

- The CPU accepts input signal from sensors like push buttons, limit switches, analog sensors, selector switches, and thumbwheel switches.
- Stores the status of input in the memory area called input image table.
- Execute the stored user program from memory and sends appropriate output commands to control devices like lamp, motor starters, solenoid valves, pilot lights, and position valves through output image table.

- Update the content of output image table.
- The system power supply provides all the voltages required for the proper operation of the various central processing unit sections.

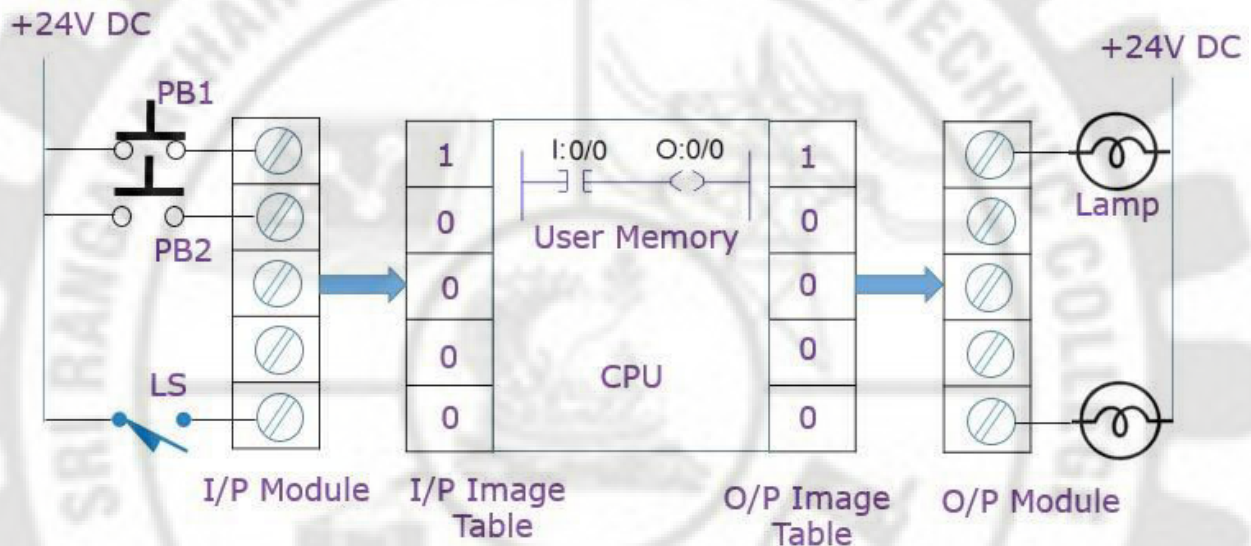

Figure 4.2 (a) Principle of Operation

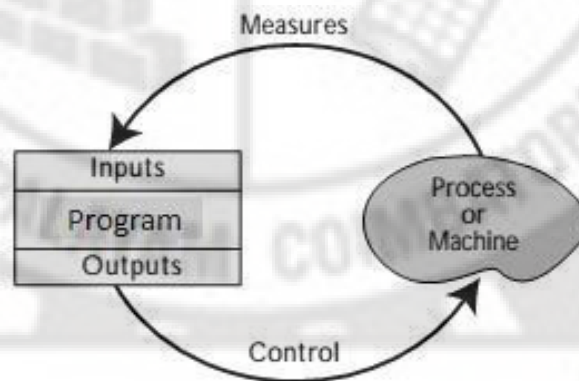

Figure 4.2 (b) Operating Sequence

Modes of Operation:

Run Mode:

- ✓ Places the processor in the RUN mode.
- ✓ Executes the ladder program and energizes output devices.
- ✓ Prevents online program editing.

PROG Mode:

- ✓ Places the processor in the program mode.
- ✓ Allows you to perform program entry and editing.
- ✓ Prevents the processor from scanning or executing the ladder program.

REM Mode:

- ✓ Places the processor in the Remote mode.
- ✓ Allows you to change the processor mode from a program/operator device.

- ✓ Allows you to perform online programmed editing.

PLC Scan:

PLC scan is a sequential process in which the PLC processor performs specific duties on a cyclic basis. During its operation, the CPU completes three processes:

- i) **Reads** the input data from the field devices via the input interfaces
- ii) **Executes** the control program stored in the memory system
- iii) **Writes** the output devices via the output interfaces.

This process of sequentially reading the inputs, executing the program in memory, and updating the outputs is known as **scanning**. Figure 4.3 illustrates a graphic representation of a scan.

In each process cycle, the processor begins by reading or taking a snapshot of the status of the devices connected to input modules and storing the ON/OFF status of each in a special memory called the input image table. After the inputs have been read and stored in the input image table, the processor executes the control program.

During program execution, the processor evaluates the conditions of each statement by looking back at the input image table to see if the input condition are met. If the conditions controlling an output are met, the processor immediately writes a 1 in a special memory called output image table.

The scan time is the specific amount of time required for a PLC to perform both the I/O scan and the program scan. Each PLC's scan time is different. The PLC scan time specification indicates how fast the controller can react to changes in inputs. Scan time varies with program content and length. The time taken to scan the user program is also dependent on the clock frequency of the microprocessor system.

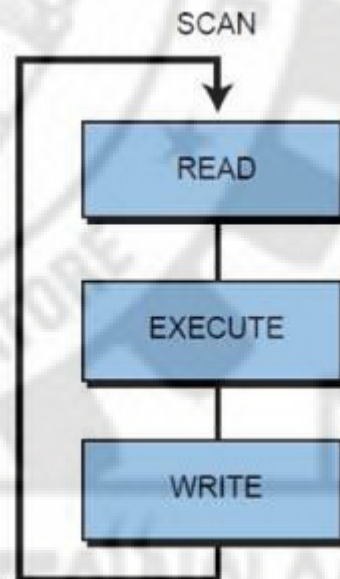

Figure 4.3 PLC Scan

Memory Organization;

The memory system is composed of two major sections:

1. System memory
2. Application memory

Figure 4.4 illustrates this memory organization, known as a **memory map**.

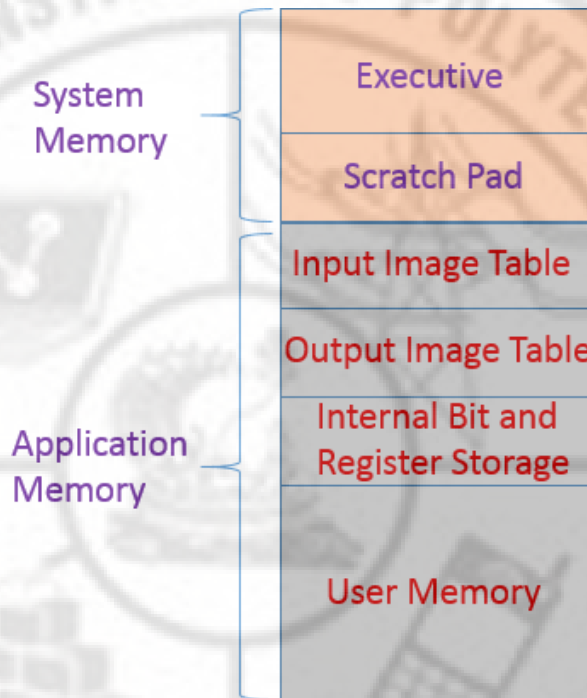

Figure 4.4 Memory Organisation

1. SystemMemory:

The executive and scratch pad areas are hidden from the user and can be considered a single area of memory that, for our purpose, is called *systemmemory*.

i) Executive Area:

The executive is a permanently stored collection of programs that are considered part of the system itself. These supervisory programs direct system activities, such as execution of the control program, communication with peripheral devices, and other system housekeeping activities.

ii) Scratch PadArea:

This is a temporary storage area used by the CPU to store a relatively small amount of data for interim calculations and control. The CPU stores data that is needed quickly in this memory area to avoid the longer access time involved with retrieving data from the main memory.

2. ApplicationMemory:

The application memory stores user programs and any data the processor will use to perform its control functions.

i) Input ImageTable:

The portion of memory area used to store the status of input field devices is called input image table. If the input switch is ON, the corresponding bit will be set as 1. During PLC operation, the processor will read the status of each input in the input module and place a value (1 or 0) in the corresponding address in the input image table.

ii) **Output Image Table:**

The portion of memory area used to store the status of output field devices is called output image table. The output table is an array of bits that controls the status of digital output devices that are connected to the PLC's output interface. If a bit in the table is turned ON, then the connected output is switched ON.

iii) **Internal Bit and Register storage:**

The internal bit storage area contains storage bits that are referred to as internal outputs, internal coils, and internal relays. These internals provide an output, for interlocking purposes, of ladder sequences in the control program. The register/word storage area is used to store groups of bits (bytes and words).

iv) **User Memory:**

This area provides storage for programmed instructions entered by the user. The user program area also stores the control program.

Factors affecting the memory size of PLC:

1. Number of I/Os
2. Size of control program
3. Data collecting requirements
4. Supervisory functions required
5. Future Expansion

Input Module (Schematic and Wiring Diagram):

The main purpose of input module is to take the input signal from the field device and convert it to a signal that can be processed by the PLC CPU. In addition, the input module provides electrical isolation between the input field devices and PLC CPU.

Types of input Module:

1. Discrete input module
 - a. AC Discrete input module
 - b. DC Discrete input module
2. Analog input module

These are used to connect the sensors that provide the analog electric signals. Inside these modules, analog to digital converter is used to convert the analog to processor understandable data, i.e., digital data.

Discrete InputModule:

These are used to connect the sensors that are of digital in nature, i.e., only for switch ON and OFF purpose. These modules are available on both AC and DC voltages and currents with variable number of digital inputs.

AC Discrete inputModule:

Figure 4.5 (a) and (b) shows a schematic and circuit diagram of a typical AC Discrete input module.

It has three primary parts:

- i) Powersection
- ii) Isolatorsection
- iii) Logic section

i) PowerSection:

The bridge rectifier circuit of the power section converts the incoming AC signal to a DC-level signal. It then passes the signal through a filter circuit, which protects the signal against bouncing and electrical noise on the input power line. Threshold circuit detects if the incoming signal has reached or exceeded a predetermined value for a predetermined time.

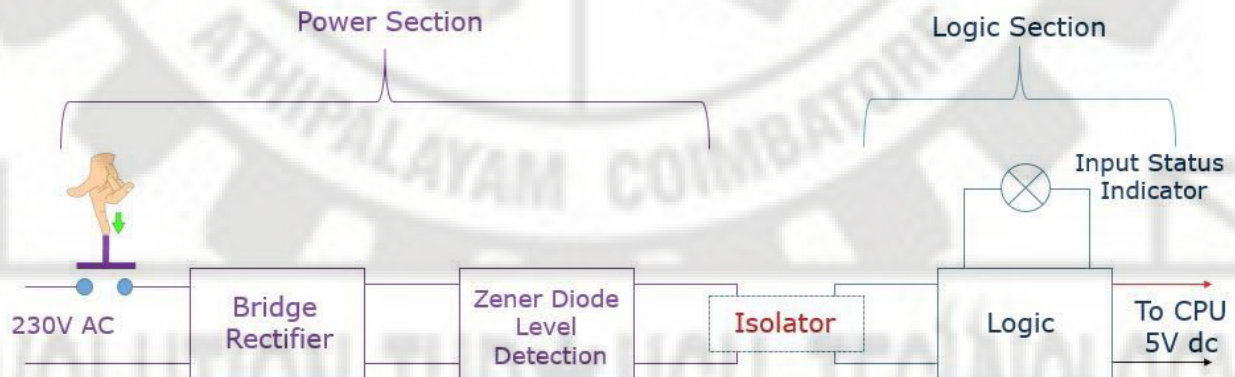

Figure 4.5 (a) Schematic Diagram of AC Discrete Input Module

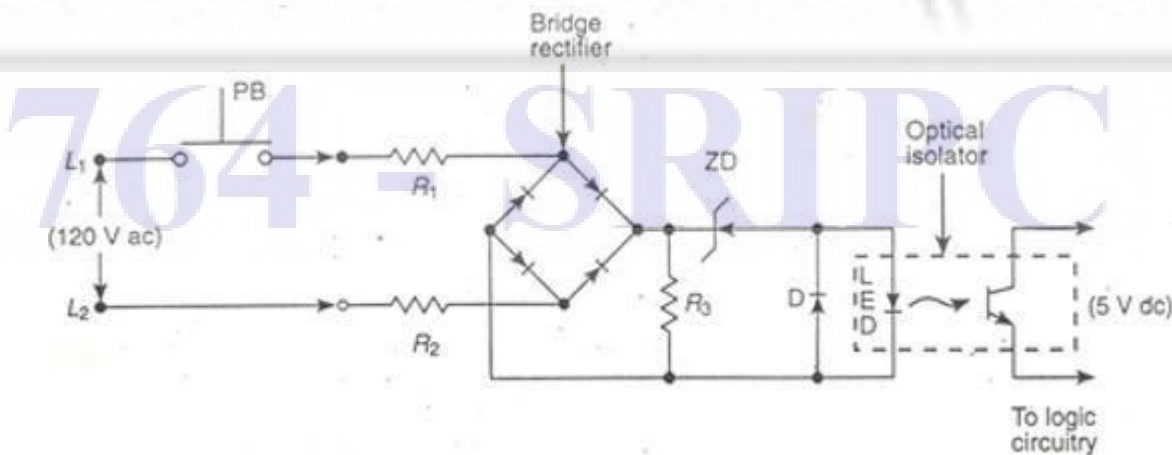

Figure 4.5 (b) Circuit Diagram of AC Discrete Input Module

ii) Isolator section:

After the detection of a valid signal, it passes the signal to logic section through an isolation circuit. The isolator circuit is usually made up of an optical isolator (called as opto-coupler). It is used to isolate the logic circuit from power circuit.

This optical isolation helps to reduce the effect of electrical noise and Prevents damage to the processor due to line voltage transient.

ii) Logic Section:

DC signals from the opto-coupler are used by the logic section to pass the input signal to the CPU. The LED in the logic circuit is used to indicate the presence of a logic 1 signal in the logic section.

LED glow - input signal is present

LED not glow - input signal is not present.

DC Discrete input Module:

Figure 4.5 (a) and (b) shows a circuit diagram of a typical DC Discrete input module.

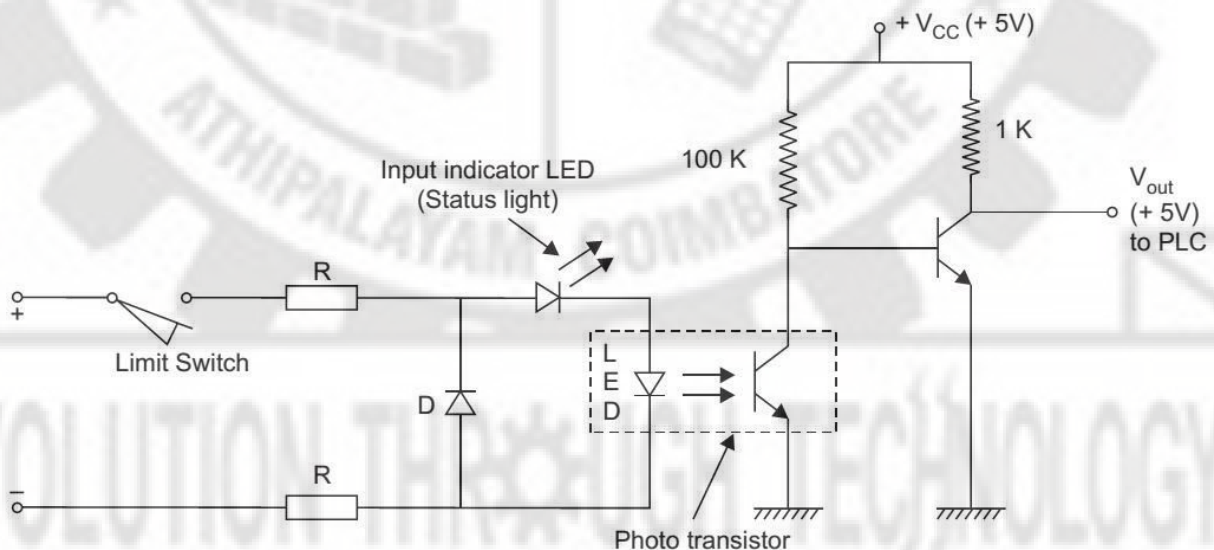

Figure 4.6 Circuit Diagram of DC Discrete Input Module

i) Power section:

A DC input module interfaces with field input devices that provide a DC output voltage. The difference between a DC input interface and an AC/DC input interface is that the DC input does not contain a bridge circuit, since it does not convert an AC signal to a DC signal. The input voltage range of a DC input module varies between 5 and 30 VDC.

ii) Isolator section:

After the detection of a valid signal, it passes the signal to logic section through an isolation circuit. The isolator circuit is usually made up of an optical isolator (called as opto-coupler). It is used to isolate the logic circuit from power circuit.

This optical isolation:

1. Helps to reduce the effect of electrical noise
2. Prevents damage to the processor due to line voltage transient.

ii) Logic Section:

DC signals from the opto-coupler are used by the logic section to pass the input signal to the CPU. The LED in the logic circuit is used to indicate the presence of a logic 1 signal in the logic section.

LED glow - input signal is present

LED not glow - input signal is not present

4.10.2 Analog input module:

The Analog input module is used to convert analog signal from analog devices, such as analog sensors, temperature probes, pressure indicator etc., to equivalent digital values using analog to digital converter. The analog input signal is usually a varying voltage in the range of 0-10V or current in the range of 4-20mA. The transformed analog value is the digital equivalent of the analog input signal. Each converter value is stored in the memory in a digital form, typically as a 16-bit word for internal processing. They provide optical isolation for electrical noise protection.

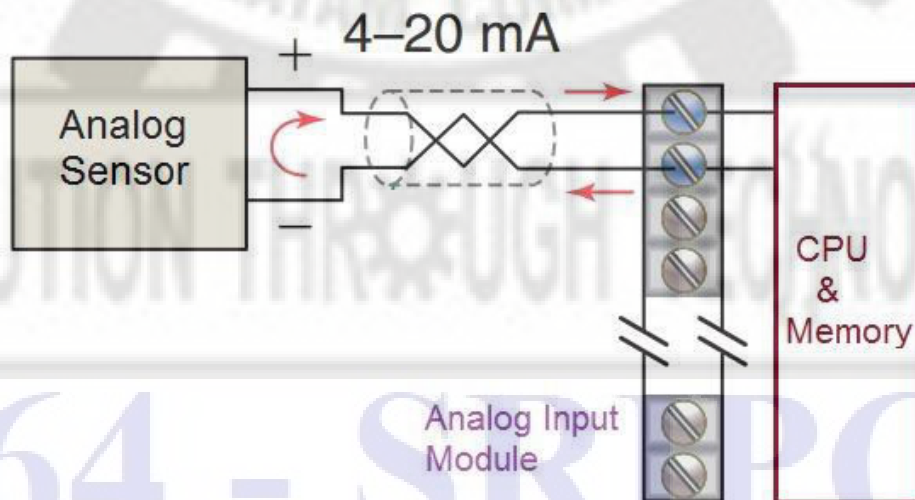

Figure 4.7 Schematic diagram of Analog Input Module

Output Module (Schematic and Wiring Diagram):

The main purpose of the output module is to take the signal from the PLC CPU and convert it to a signal for the field device. In addition, the output module provides electrical isolation between the PLC and the output field device.

Types of output Module:

1. Discrete outputmodule
 - a. AC Discrete OutputModule
 - b. DC Discrete OutputModule
2. Analog outputmodule

Discrete OutputModule:

Discrete output module produces output signals that are either OFF or ON. Digital output modules are available for DC output, AC outputs or a mix.

A.C Discrete OutputModule:

Figure 4.6 (a) and (b) shows a schematic and circuit diagram of A.C Discrete output Module. The circuit consists of logic and power sections, coupled by an isolation circuit.

i) LogicSection:

During normal operation, the processor sends an output's status, according to the logic program, to the module's logic circuit. If the output is to be energized, the logic section of the module will latch, or maintain, a 1. This sends an ON signal through the isolation circuit, which in turn, switches the voltage to the field device through the power section of the module. The LED in the logic circuit is used to indicate the presence of a logic 1 signal in the logic section.

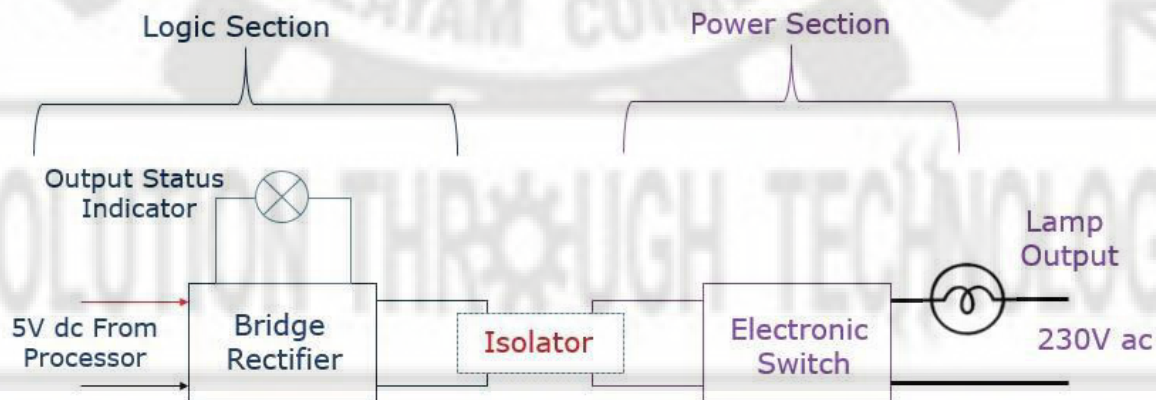

Figure 4.8 (a) Schematic Diagram of AC Discrete Output Module

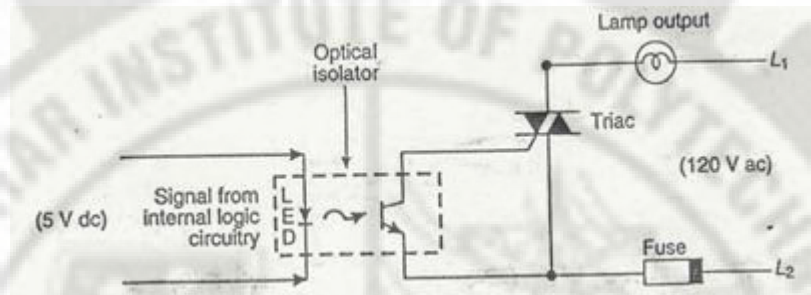

Figure 4.8 (b) Circuit Diagram of AC Discrete Output Module

ii) Isolator section:

After the detection of a signal from CPU, it passes the signal to power section through an isolation circuit. The isolator circuit is usually made up of an optical isolator (called as optocoupler). It is used to isolate the logic circuit from power circuit. This electrical separation helps prevent large voltage spikes from damaging either the logic side of the interface or the PLC.

iii) Power section:

The switching circuit in the power section of an AC output module uses either a TRIAC or SCR to switch power. The AC switch is normally protected by an RC snubber or a metal oxide varistor (MOV). This snubber and MOV circuits prevent electrical noise from affecting the circuit operation. Furthermore, an AC output circuit may contain a fuse that prevents excessive current from damaging the switch.

D.C Discrete Output module:

This circuit of D.C Output module is shown in figure 4.7 (b). The circuit consists primarily of the logic and power sections, coupled by an isolation circuit.

i) Logic Section:

During normal operation, the processor sends an output's status, according to the logic program, to the module's logic circuit. If the output is to be energized, the logic section of the module will latch, or maintain, a 1. This sends an ON signal through the isolation circuit, which in turn, switches the voltage to the field device through the power section of the module. The LED in the logic circuit is used to indicate the presence of a logic 1 signal in the logic section.

764 - SRIPC

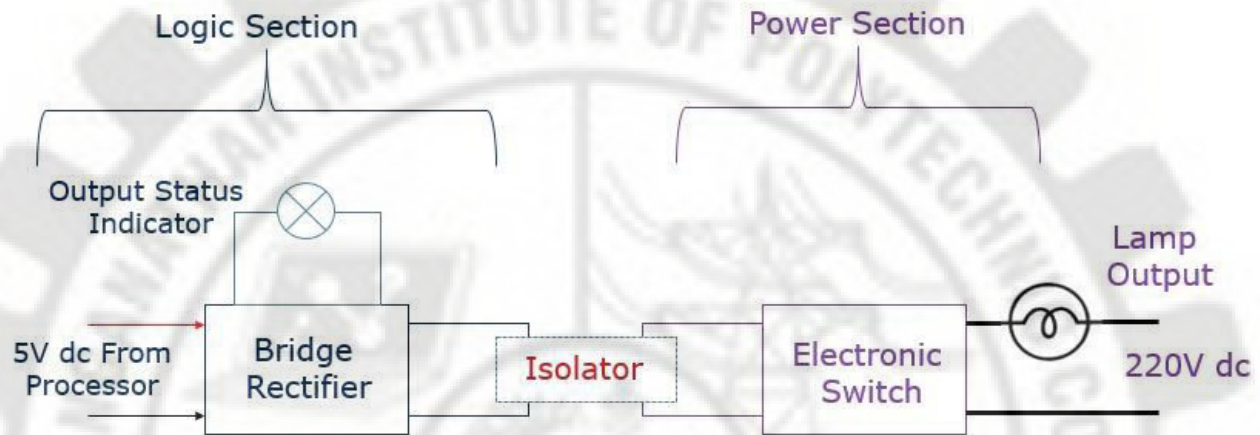

Figure 4.9 (a) Schematic Diagram of DC Discrete Output Module

ii) Isolator section:

After the detection of a signal from CPU, it passes the signal to power section through an isolation circuit. The isolator circuit is usually made up of an optical isolator (called as optocoupler). It is used to isolate the logic circuit from power circuit. This electrical separation helps prevent large voltage spikes from damaging either the logic side of the interface or the PLC.

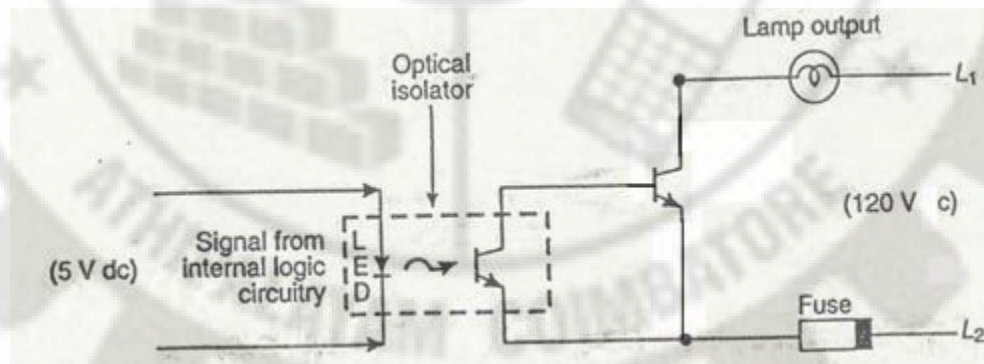

Figure 4.9 (b) Circuit Diagram of DC Discrete Output Module

iii) Power section:

The switching circuit in the power section of an DC output module uses a power transistor to switch ON the load. The AC switch is normally protected by a freewheeling diode across the load. DC outputs may also incorporate a fuse to protect the transistor during moderate overloads.

Example of Output Field Devices:

1. Alarms
2. Control relays
3. Fans
4. Horns
5. Lights
6. Motor starters
7. Solenoids
8. Valves

Output Ratings:

- 12–48 volts AC/DC
- 120 volts AC/DC
- 230 volts AC/DC
- Contact (relay)
- Isolated output
- TTL level
- 5–50 volts DC (sink/source)

4.11.2 Analog Output Module:

The analog output modules convert processed digital values from the CPU into equivalent analog signals, typically in the range of 0 -10V or 4 -20mA, to operate analog output devices using digital to analog converter. Analog output module is used in applications requiring the control of field devices that respond to continuous voltage or current levels. This analog output value is proportional to the digital numerical value received by the module. Thus, the D/A converter creates a continuous analog signal with a magnitude proportional to the minimum and maximum capable analog voltages or currents of the field device.

Analog output modules are selected to send out either a varying current or voltage signal. An analog output could send a 4 to 20mA signal to a variable speed drive. The drive will control the speed of a motor in proportion to the analog signal received from analog output module.

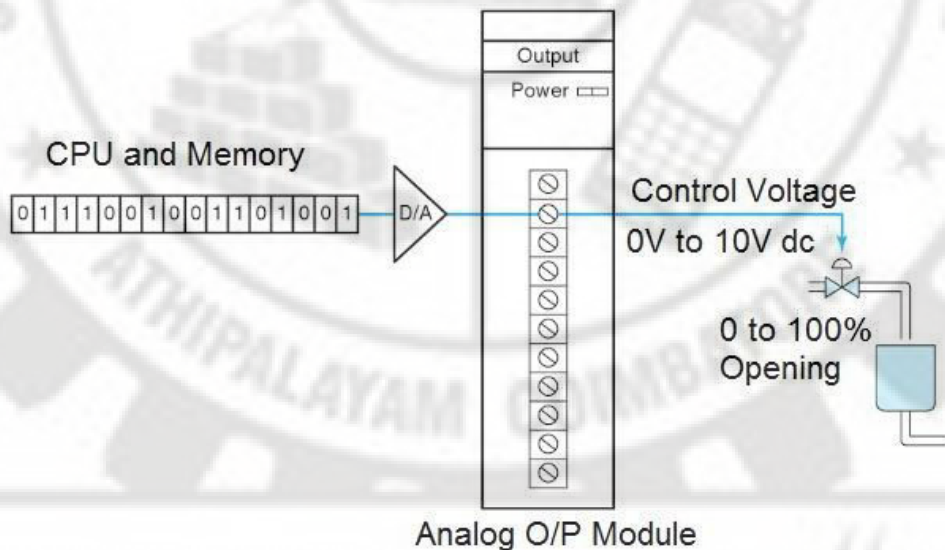

Figure 4.10 Schematic Diagram of Analog Output Module

Example of analog output field devices: Analog valves, Actuators, Chart recorders, Electric motor drives, analog meters and pressure transducers.

Types of Programming Device:

Programming device:

- ✓ A Programming device is needed to enter, modify, monitor and troubleshoot the PLC program.
- ✓ Once the program has been entered and the PLC is running, the programming device may be disconnected.

Types of programming Device:

1. Hand held Instrument
2. Dedicated Desktop programmer
3. Personal Computer

Hand held Instrument:

A hand held programmers are smaller, cheaper and more portable. This unit contain multicolored, multifunction keys, and LCD or LED display window. The keys are used entering and editing the instruction, navigation keys for moving around the program. It has minimum display capability. It is well suited for parameter changes in the user program.

Advantages of hand held instrument:

1. Easy transfer of PLC program
2. Low cost
3. Easy to use and easy to learn
4. Compact size
5. Works with industrial environment



Figure 4.11 Handheld Instrument

Disadvantages of hand held instrument:

1. Limited ladders can be displayed
2. Documentation not displayed
3. Program stored in the memory will be lost when battery is failure.
4. Need more keystroke to enter the program
5. Take more time to enter a big program
6. Modification of program is difficult.

Dedicated Desktop programmer:

It is designed for programming and monitoring the PLC. They are not capable of performing other computer functions. It consists of a keyboard, Video Display Terminal (VDT) and necessary electronic circuits and memory unit. Most dedicated programmer keyboards have electrical symbol keys for NO, NC, Timers etc., VDT is used to give visual display of the program.

Advantages of Dedicated desktop programmer:

1. Portable and withstand the mechanical shock
2. It can work with industrial environment
3. Not affected by electrical noise, high temperature and humidity
4. Easy for electrician or technician to enter or modify the program.



Figure 4.12 Dedicated Desktop of Industrial Computer

764 - SRIPC

Personal Computer:

With software available for all major brands of PLCs, the PC is now most common programming device.

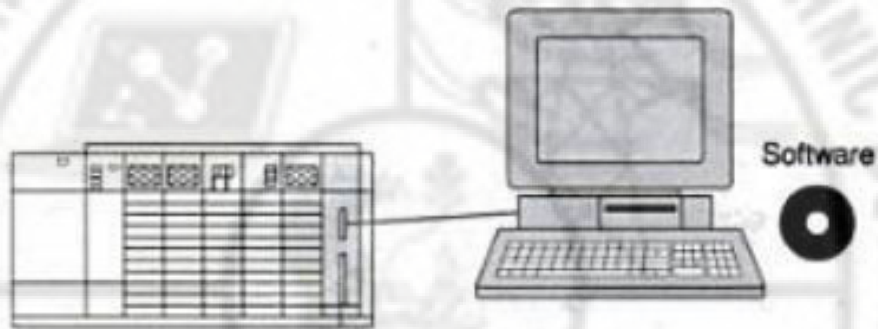

Figure 4.13 Personal Computer (PC)

Advantages of PC programmer:

1. It can display multiplerungs
2. Easy for trouble shootingoperation
3. Program can stored on the computer harddisk
4. Program can be stored in floppy, pen driveetc.,
5. Running comments, symbols and other related text can bedisplayed.
6. Data table can be easilymonitored.
7. Easy editing and modifying theprogram

Disadvantages of PC programmer:

1. PC is not designed for industrialenvironment
2. It is affected by electrical noise, temperature andhumidity

764 - SRIPC

Comparison between hardwire controlsystem and PLCSystem:

#	Criterion for comparison	PLC	Hardwired
1	Requirement of Instruction	Instructions are required	Instructions are not required
2	Time required for modification	Less time	More time
3	Memory Requirement	Memory is required for storing the program	Memory is not required
4	Cost	Initial cost is high	Initial cost is low
5	Power Consumption	Less	High
6	Space Required	Small	Large
7	Heat generated	Less	High
8	Technology	Latest	Old
9	Fault identification	Easy	Not easy
10	Error Correction	Easy	Not easy
11	Control circuit	No control circuit. It is controlled by program	Control circuit involves lot of internal wiring

PLC Types (Fixed and Modular):

FixedPLC:

This PLC has the sections like input module, CPU and associated memory, power supply and output module. These sections are built into one self-contained unit. Fixed PLCs are also referred as “Shoebox” or “brick” by manufacturers due to their shape and size. In this type the number of inputs and outputs cannot be expanded.

Example : Allen Bradley Micrologic 1000 has 6 discrete inputs and 4 discrete outputs.

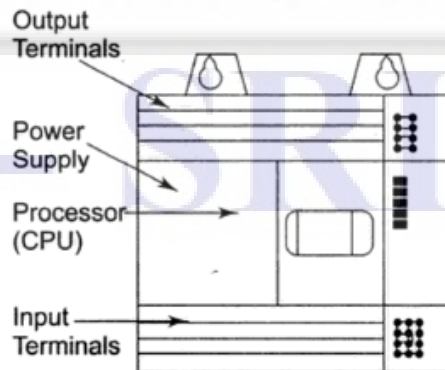

Figure 4.14 Fixed I/O PLC

Advantages:

- i) Less scanningtime
- ii) Lowcost
- iii) Less trouble shootingtime

Disadvantages:

- i) Limited number of inputs andoutputs
- ii) Not suited for futureexpansion
- iii) If part of the unit fails, need to replace entireunit.

ModularPLC:

A modular PLC is built with several components that are plugged into a common rack with extendable I/O capabilities. It consists of a rack, power supply, CPU and I/O modules. On a rack these modules are fixed as separate hardware items. Modular PLCs are further divided into small, medium and large PLCs based on the program memory size and the number of I/O features.

Example:Siemens: S7-300 andS7-400
Allen Bradley: SLC 5/01, SLC 5/02 etc.,

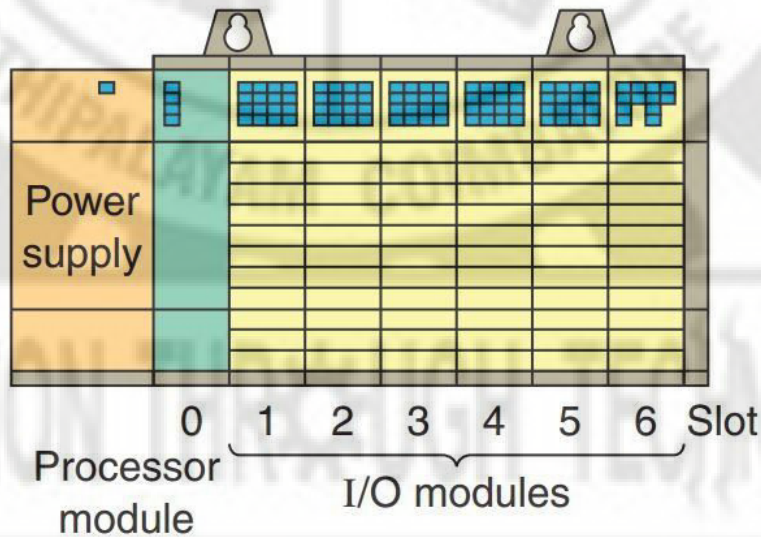

Figure 4.15 Modular I/O PLC

InputTypes:

- 1. Logic
- 2. Analog

Logic:

PLC can only understand a signal that is ON or OFF. Binary 1 indicates that a signal is present, or the switch is ON. Binary 0 indicates that the signal is not present or the switch is OFF.

The logic concept exists only in two predetermined states. In logic input (digital) systems, these two-state conditions can be thought of as signals that are present or not present, activated or not activated, high or low, on or off, etc.

Here, binary 1 represents the presence of a signal, while binary 0 represents the absence of the signal. In digital systems, these two states are actually represented by two distinct voltage levels, +V and 0V. One voltage is more positive than the other. Often, binary 1 (or logic 1) is referred to as TRUE, ON, or HIGH, while binary 0 (or logic 0) is referred to as FALSE, OFF, or LOW.

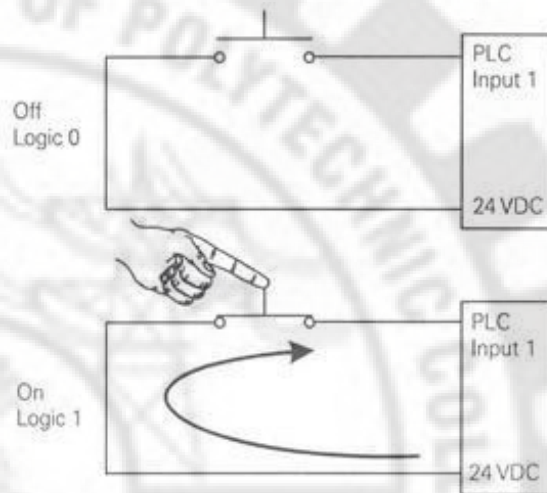

Figure 4.16 Logic Input

Digital Inputs include push-buttons, limit switches, relay contacts, proximity switches, photo sensors (On/Off), pressure switches and more. Digital inputs devices are available in both DC as well as AC and some are voltage independent such as a switch contact.

Analog:

An analog input is an input signal that has a continuous signal. Analog input modules, are used in applications where the field device’s signal is continuous. Typical analog inputs may vary from 4 to 20mA or 0-10 volts d.c. Analog signals are used to represent changing values such as speed, temperature, weight and level. This analog signal is converted into binary data that can be stored in the data table and used by the PLC when it solves the PLC program.

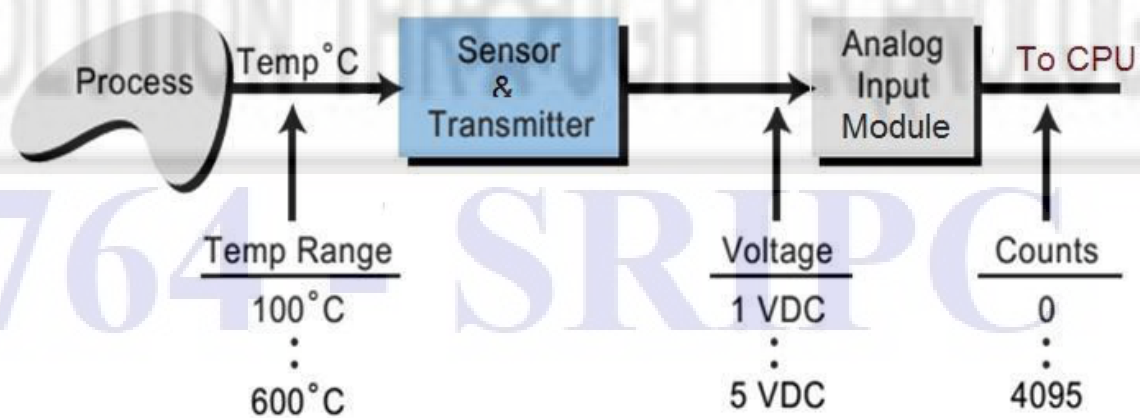

Figure 4.17 Analog Input

OutputTypes:

- i) Logic (Discrete) output
- ii) AnalogOutput

DigitalOutput:

A discrete output can either turns a device ON or OFF such as lights, LEDs, small motors, and relays. Some examples are motors that need just be ON or OFF, Lighting, solenoid valves, door locks. Digital output modules are available for DC output, AC output or a mix.

Typical digital output devices are:

- i) Motor startercoils
- ii) Pilotlights
- iii) Solenoids
- iv) Alarms
- v) Controlrelays
- vi) Horns
- vii) Start / stop signals toVFD/VSD

AnalogOutput:

Analog output (AO) are for variable level or range of output between OFF or stopped and ON or full speed as for an electric motor for instance. Examples of analog outputs are a VFD (Variable Frequency Drive), a valve position actuator, and a industrial variable power supply.

The output signal can be divided into 32,767 increments and represented in a 16 bit word. To achieve precision in controlling the valve, the 0 to 10volt signal will be split into 32,767 steps. Since the output module automatically converts the 16 bit output word to the proper analog value.

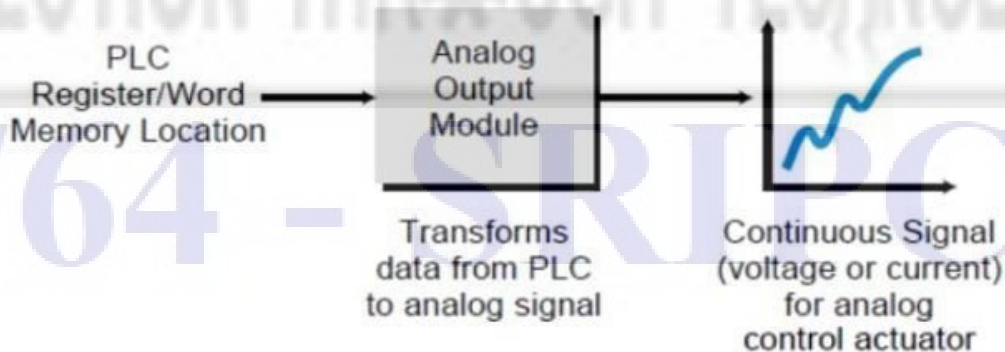

Figure 4.18 Analog Output

Example of analog output could be a valve in a tank filling application. The positioning of the valve can be represented by a voltage level of zero volts when the valve is closed and upto +10V dc when the valve is completely open. Any voltage between 0V dc and 10V dc would represent how far open the valve would be compared to its fully open state. The analog output module transforms a digital

Typical analog output devices are:

- i) Analog valves
- ii) Actuators
- iii) Chart recorders
- iv) Electric motor drives
- v) Analog meters
- vi) Pressure transmitter

Typical analog signals are:

- i) 0 to 10V d.c
- ii) -10 to +10V d.c
- iii) 0 to 5V d.c
- iv) 1 to 5 V d.c
- v) 0 to 20mA
- vi) -20 to +20mA
- vii) 4 to 20mA

Criteria for selection of suitable PLC:

The process of selecting a PLC is listed below:

1. List the number and types of Input & Output.
2. Memory capacity needed to store the program
3. Speed of processing
4. Communication requirements
5. Special or specific modules required
6. Consider safety, reliability and expandability

List of various Brands of PLCs available:

1. SIEMENS
2. Allen Bradley
3. Omron
4. GE Fanuc
5. MODICON
6. Keyence
7. Mitsubishi
8. Toshiba
9. Honeywell
10. Festo Corp.

Advantages of PLC:

The major advantages of PLC circuit over hardwired relay panel circuits are listed below:

1. Flexibility
2. Large quantity of contacts
3. Speed of operation
4. Reliability & Security
5. Documentation
6. Fail safe operation
7. New technology
8. Less power consumption
9. Required less floorspace
10. Fault location and rectification is easy
11. Logic changes can be reprogrammed
12. Ladder programming method
13. Documentation
14. Pilot running

Applications of PLCs:

- Conveyor Systems,
- Food Processing Machinery,
- Bottle filling (water, soft drinks, canned food)]
- Auto Assembly (e.g. automobile industry)
- Fluid Level Control (e.g. water tanks)
- Mixing Fluids (paint industries)
- Motor speed control

REVOLUTION THROUGH TECHNOLOGY

764 - SRIPC

UNIT – IV PROGRAMMABLE LOGIC CONTROLLER

MODEL QUESTIONS

Two Mark Questions:

1. Define the term automation.
2. What are the advantages of fixed automation?
3. What are the advantages of programmable automation?
4. What are the advantages of flexible automation?
5. Give any two examples for office automation.
6. Give any two examples for home automation.
7. Give any two examples for building automation.
8. State any two advantages of automation.
9. What are the major parts of a PLC?
10. What are the different operating modes of a PLC?
11. What is the use of input module?
12. What is the use of output module?
13. List the types of input module.
14. What is the function of input module?
15. List the types of output module.
16. What is the function of output module?
17. What are the three sections of an A.C input module?
18. Give any two examples for discrete input devices.
19. Give any two examples for analog input devices.
20. Give any two examples for discrete output devices.
21. Give any two examples for analog output devices.
22. List the name of any two PLC programming devices.
23. State the advantages of fixed PLC.
24. What is a modular PLC?
25. List the name of any two market available PLC.

Three Mark Questions:

1. What are the types of automation?
2. List the advantages of automation.
3. Explain about fixed automation.
4. Explain about programmable automation.
5. Explain about flexible automation.
6. What do you know about office automation?
7. What do you know about home automation?
8. What do you know about building automation?
9. Define PLC

10. Write short notes on modes of operation of PLC
11. Draw the block diagram of A.C discrete input module
12. Write short notes on PLC scan.
13. What are the advantages of hand held instrument?
14. What are the advantages using PC as a programming device for PLC?
15. List the advantages of dedicated desktop.
16. Compare PLC circuit versus hardwired circuits. (any 3)
17. Write short note on logic input in PLC.
18. Write short note on analog input in PLC.
19. Write short note on discrete output in PLC.
20. Write short note on analog output in PLC.
21. Explain the operation of analog input module.
22. Explain the operation of analog output module.
23. List the criteria for selection of suitable PLC for particular application?
24. List the name of any six market available PLC.
25. List any three advantages of PLC?
26. List out few applications of PLC.

Ten Mark Questions:

1. Draw and explain the block diagram of PLC.
2. With neat sketch explain the principle of operation of PLC.
3. Draw and explain the block diagram of memory organization.
4. With neat sketch explain about PLC scan.
5. With neat sketch explain the construction of modular PLC's
6. With neat sketch explain the operation of A.C discrete input module.
7. With neat sketch explain the operation of A.C discrete output module.
8. With neat sketch explain the operation of analog input module.
9. With neat sketch explain the operation of D.C discrete output module.
10. With neat sketch explain the operation of analog output module.
11. Compare hardwire control system versus PLC system.
12. Write brief notes on logic input and analog input.

764 - SRIPC

UNIT- 5 PLC PROGRAMMING AND SCADA

OBJECTIVES:

After studying this chapter, the student will be able to:

- Explain the different types of PLC programming methods.
- Develop ladder logic using relay type instruction, Timer and counter instructions.
- Develop ladder logic diagram for DOL starter, automatic star-delta starter, Rotor resistance starter and EB to Generator change over system.

Different Programming Languages:

The IEC (International Electrotechnical Commission) has created a standard (IEC 1131-3) for five programming languages for PLC. These five languages are known as:

1. Function Block Diagram (FBD)
2. Instruction List (IL)
3. Ladder diagram (LD)
4. Sequential Function Chart (SFC)
5. Structured Text (ST)

Functional Block Diagram: (FBD)

It is a graphical language for depicting signal and data flows through functional blocks. A FBD program is constructed using function blocks that are connected together to define the data exchange. This programming language is a graphic language that uses a library of functions in combination with custom functions to create programs. The inputs and outputs of function blocks can be inverted.

Instruction List (IL):

It is a low level 'assembler like' language using text. Whenever the rung is started, it must use a rung code. Use LD to indicate the rung is starting with NO contacts and LDI to indicate the rung is starting with NC contacts. All rungs must end with an OUT i.e. output. It is best suited for small applications and fast execution.

Ladder Diagram(LD):

Ladder programming has evolved from the wiring diagrams that are used in the car industry for describing the relay control schemes. This method is easy to understand by people who are familiar with simple electronic or electrical circuits. Also it is well accepted by electrician and plant technician. Faults can be quickly traced is the advantage of this method. The ladder symbols and facilities vary between different PLC products. It has limited facilities for building complex sequences.

Sequential Function Charts(SFC):

It is a graphical language for depicting sequential behavior of a control system. It is used for defining control sequences that are time and event driven. While providing structure and coordination of sequential events, alternative and parallel sequences are supported as well. It contains Flowchart of steps and transitions.

Structured Text(ST):

It is a high level textual language that encourages structured programming. It has a language structure (syntax) that strongly resembles PASCAL. ST is an excellent language for complex processes or calculations that are not graphic friendly.

LadderDiagram:

Ladder diagrams are very similar to ladder schematics. A ladder diagram is a symbolic representation of an electrical circuit.

A very commonly used method of programming PLCs is based on the use of ladder diagrams. Writing a program is then equivalent to drawing a switching circuit. The ladder diagram consists of two vertical lines representing the power rails. Circuits are connected as horizontal lines, i.e. the rungs of the ladder, between these two verticals.

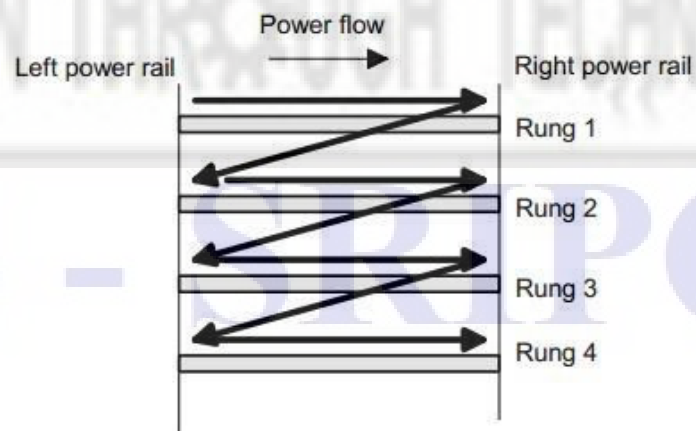

Figure: Scanning the ladder diagram

Rules for ladder diagram:

- i) The vertical lines of the diagram represent the power rails between which circuits are connected.
- ii) Horizontal lines represent rung of a ladder.
- iii) Input devices are connected towards left rail.
- iv) Output devices are connected towards right rail.
- v) A ladder diagram is read from left to right and from top to bottom. The top rung is read from left to right. Then the second rung down is read from left to right and soon.
- vi) Each rung must start with an input or inputs and must end with at least one output.
- vii) The inputs and outputs are all identified by their addresses, then notation used depending on the PLC manufacturer.

Relay type Instruction:

Relay instructions form the category of programming instructions that deals with the simple energizing and de-energizing of inputs and outputs. Contacts and coils fall into this category.

- ✓ There are two kinds of relay contact input instructions:
 - examine-if-closed
 - examine-if-open
- ✓ There are four kinds of relay coil output instructions:
 - simple output
 - internal output
 - latch/unlatch output
 - one-shot rising instructions

Instruction	Used to
XIC – Examine if closed	Examine a bit for an ON condition
XIO – Examine if open	Examine a bit for an OFF condition
OTE – Output Enable	Turn ON or OFF a bit
OTL – Output Latch	Latch a bit ON
OTU – Output Unlatch	Unlatch a bit OFF
ONS – One shot	Detect an OFF to ON transition
OSR – One Shot Rising	Detect an OFF to ON transition

OSF – One Shot Falling

Detect an ON to OFF transition

Examine if closed:(XIC)

- ✓ Typically represents any input to the control logic.
Ex: Pushbutton, contact etc.,
- ✓ It has a bit level address.
- ✓ The status bit will be either 1 (ON) or 0 (OFF).
- ✓ The status bit is examined for an ON condition.
- ✓ If the status bit is 1 (ON), then the instruction is TRUE.
- ✓ If the status bit is 0 (OFF), then the instruction is FALSE.

Examine-If-Closed



(XIC)

Examine if opened:(XIO)

- ✓ Typically represents any input to the control logic.
Ex: Pushbutton, contact etc.,
- ✓ It has a bit level address.
- ✓ The status bit will be either 1 (ON) or 0 (OFF).
- ✓ The status bit is examined for an OFF condition.
- ✓ If the status bit is 0 (OFF), then the instruction is TRUE.
- ✓ If the status bit is 1 (ON), then the instruction is FALSE.

Examine-If-Open

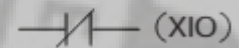

(XIO)

Output Energize:(OTE)

- ✓ It represents any output that is controlled by some combination of input logic.
- ✓ An output can be a connected device or an internal relay output.
- ✓ It has a bit level address.
- ✓ The status bit is set to 1 (ON), when the rung is TRUE.
- ✓ The status bit is set to 0 (OFF), then the instruction is FALSE.
- ✓ If the status bit is 0 (OFF), then the instruction is FALSE.

Output Coil



Output Latch:(OTL)

- ✓ It is an output instruction with a bit level address.
- ✓ When the instruction is true, it sets a bit in the output image table.
- ✓ It is a retentive instruction because the bit remains set when the latch instruction goes false.

Latch



Output Unlatch:(OTU)

- ✓ It is an output instruction with a bit level address.
- ✓ When the instruction is true, it resets a bit in the output image table.
- ✓ It is a retentive instruction because the bit remains reset when the latch instruction goes false.

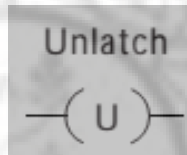

One Shot Rising :(OSR)

- ✓ A one-shot rising instruction is not a coil instruction, but rather, a contact instruction.
- ✓ This instruction is used to energize an output coil for only one scan.
- ✓ It is usually the last contact in a rung, located just before the output coil.
- ✓ This instruction's reference address bit can be located in either the binary file (file 3) or the integer file (file 7).
- ✓ Its address cannot be shared by another contact or coil, and it cannot correspond to a real input or output device.
- ✓ Also, the MicroLogix allows only one one-shot rising instruction per rung.

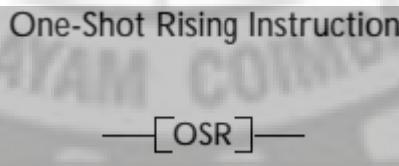

Timer Instruction:

- ✓ Timers are output instructions.
- ✓ Timing instructions are programming instructions that replace the need for electromechanical timers.
- ✓ It is used to activate or deactivate a device after a preset interval of time.
- ✓ The advantages of PLC timer:
 - Their settings can be altered easily.
 - Timer accuracy and repeatability are extremely high.
- ✓ Allen Bradley PLC 5 and SLC – 500 PLC timer elements each take three data table word: *the control word, preset word and accumulated word.*
- ✓ **The control word** uses three control bits: EN, TT & DN
 - ✓ **Enable bit (EN):** *The enable bit is true whenever the timer instruction is true. When the timer instruction is false, the enable bit is false.*

- ✓ **Timer Timing bit (TT):** The timer timing bit is true whenever the accumulated value of the timer is changing which means the timer is timing. When the timer is not timing, the accumulated value is not changing, so the timer timing bit is false.
- ✓ **Done bit (DN):** The done bit changes state whenever the accumulated value reaches the preset value.

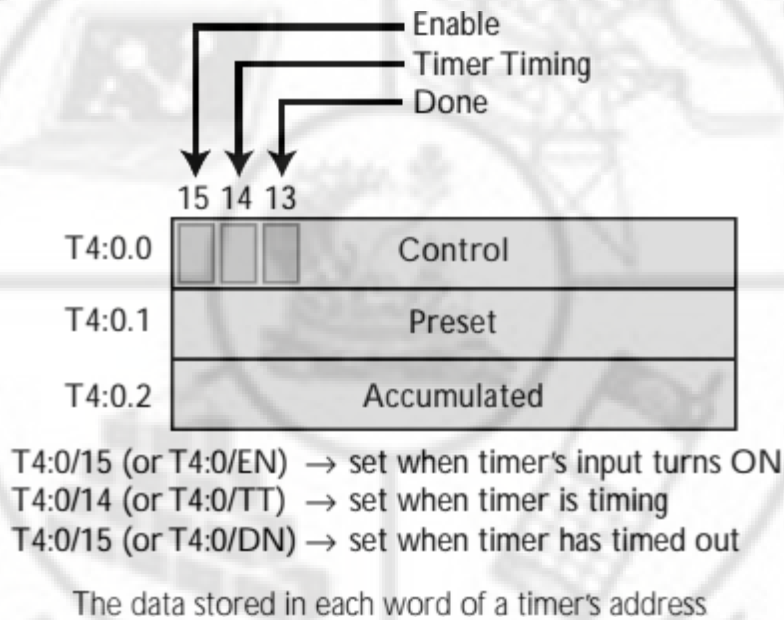

- ✓ **Preset:(PRE)**
 - The preset word is the set point of the timer.
 - The preset word has a range of 0 through 32767 and is stored in binary form.
 - The preset will not store a negative number.
- ✓ **Accumulated:(ACC)**
 - The accumulated value word is the value that increments as the timer is timing.
 - The accumulated value will stop incrementing when its value reaches the preset value.

Time base:

- ✓ Timer instruction also requires that you enter a time base which is either 1.0s or 0.01 s or 0.001s.
- ✓ Actual time delay = Preset Value x Time base
 Ex: Preset value = 50, Time base = 0.01s,
 Actual Time delay = Preset value x time base = 50 x 0.01s = 5 sec.

Types of Timer Instruction:

1. Timer ON delay (TON)
2. Timer OFF delay (TOF)
3. Retentive timer (RTO)

Timer ON Delay Instruction:(TON)

- ✓ The timer ON-delay instruction is a block-format instruction that is represented by the symbol shown in Figure below.
- ✓ This block has two outputs:
 - an enable output coil(EN)
 - a done output coil(DN)
- ✓ A timer ON-delay instruction energizes its done output (DN) after the timer block’s input turns on and a specified delay has occurred.
- ✓ This instruction is sometimes called a timer ON-delay energize instruction.
- ✓ When the timer block’s input has logic continuity, the block’s enable output (EN) will turn on. As a result, a 1 will be stored in bit 15 of the timer’s control word.
- ✓ Once the timer is enabled, it will start to time. Thus, a 1 will be stored in bit 14, which is the timer timing bit.



- ✓ As the timer times, the accumulated value increases until it equals the preset value. At that point, the timer timing bit (TT) will become a 0, and the done bit (DN) will become a 1, meaning that the done output (DN) will turn on.
- ✓ This done output (DN) is the timer’s delay action contact.
- ✓ The length of the time delay can be adjusted by changing the preset value.

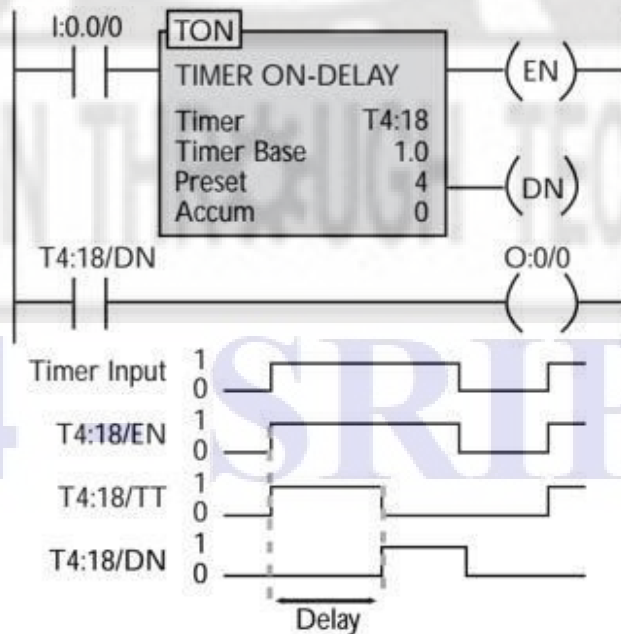

Figure: A timer ON-delay block and its associated timing diagram

Sequence of operation:

1. When the input I:0.0/0 is closed, it will cause the timer's enable output (EN) to turn ON.
2. At the same time the timer starts counting and counts until the accumulated value equals the preset value.
3. For example the preset time for this timer is 4 seconds.
4. When the accumulated value reaches 4 seconds, the done bit (DN) goes from false to true and timer timing bit (TT) goes from true to false and causing the output coil O:0/0 to turn on.
5. When input I:0.0/0 goes false, the timer instruction goes false and also resets, at which time the control bits are all reset and the accumulated value resets to 0.

Timer OFF Delay Instruction:(TOF)

- ✓ The timer OFF delay instruction is also a block-format instruction that is represented by the symbol shown in Figure below.
- ✓ This block has two outputs:
 - an enable output coil(EN)
 - a done output coil(DN)
- ✓ A timer OFF delay instruction de-energizes its done output (DN) after the timer block's input turns off and a specified delay has occurred.
- ✓ Thus, the timer OFF delay instruction is also called a timer OFF-delay de-energize instruction.

764 - SRIPC

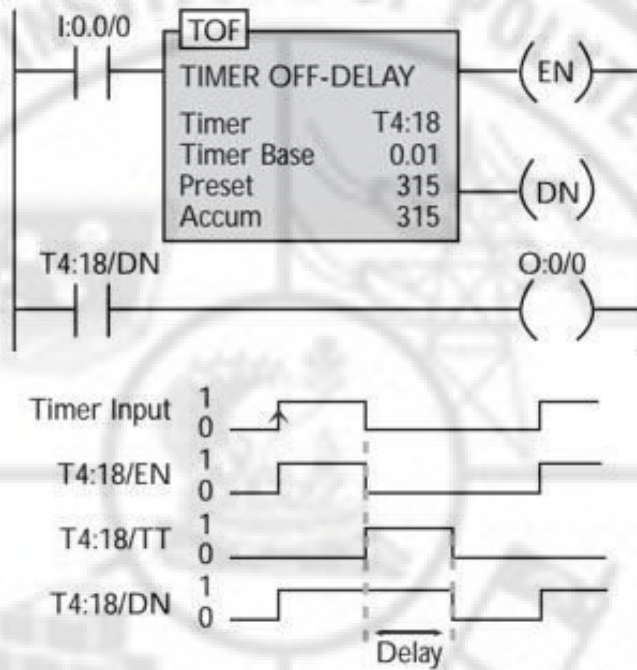

Figure: A timer OFF-delay block and its associated timing diagram

Sequence of Operation:

- ✓ The done output (DN) will be off when the program is first started and the timer's input is off.
- ✓ When the input logic turns on, both the block's enable output (EN) and done output (DN) will turn on. However, the timer will not start timing because it is waiting for an OFF signal instead of an ON signal.
- ✓ When the block's input turns off, the enable output will turn off and the timer will start timing. The done output will stay on because it is waiting for the timer to time out before it will turn off.
- ✓ Once the accumulated value equals the preset value, the timer will stop timing and the done output (DN) will turn off, implementing the OFF-delay de-energize function.
- ✓ This done output (DN) is the timer's delay action contact.
- ✓ The length of the time delay can be adjusted by changing the preset value.

Retentive Timer Instruction:

Retentive Timer ON :(RTO)

A retentive timer instruction operates much like a timer ON-delay instruction. A retentive timer, however, can stop timing and then start timing again without its accumulated value resetting to 0.

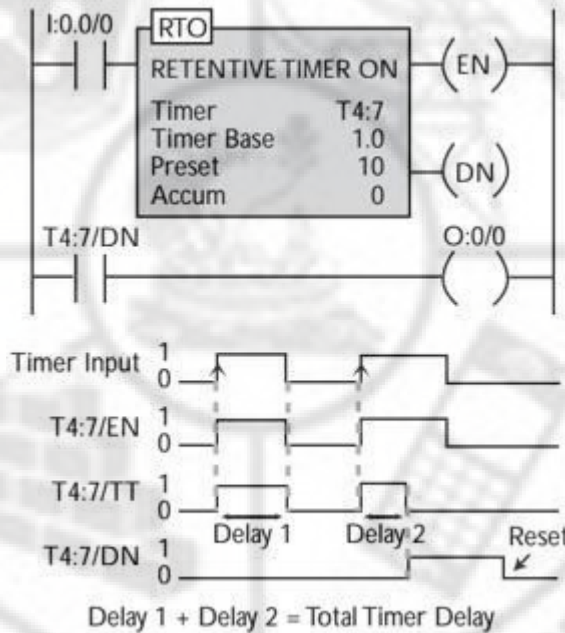

- ✓ When the input logic turns on, the enable output will turn on, and the timer will start timing.
- ✓ If the input logic turns off, the enable output will turn off, and the timer will stop timing.
- ✓ The accumulated value, however, will not reset to 0.
- ✓ When the timer starts timing again, it will pick up where it left off.
- ✓ When the accumulated value finally reaches the preset value, the done output will turn on.
- ✓ Once a retentive timer has timed out, its done output will remain on even if its input logic and enable output turn off.
- ✓ A reset instruction must be used to turn the done output off and reset the timer's accumulated value.
- ✓ The RES instruction has the same address as the timer it is to reset.

764 - SRIPC

Cascading Timers

Cascading Timer:

The programming of two or more timers together is called cascading. The timer can be interconnected or cascaded to satisfy any required control logic.

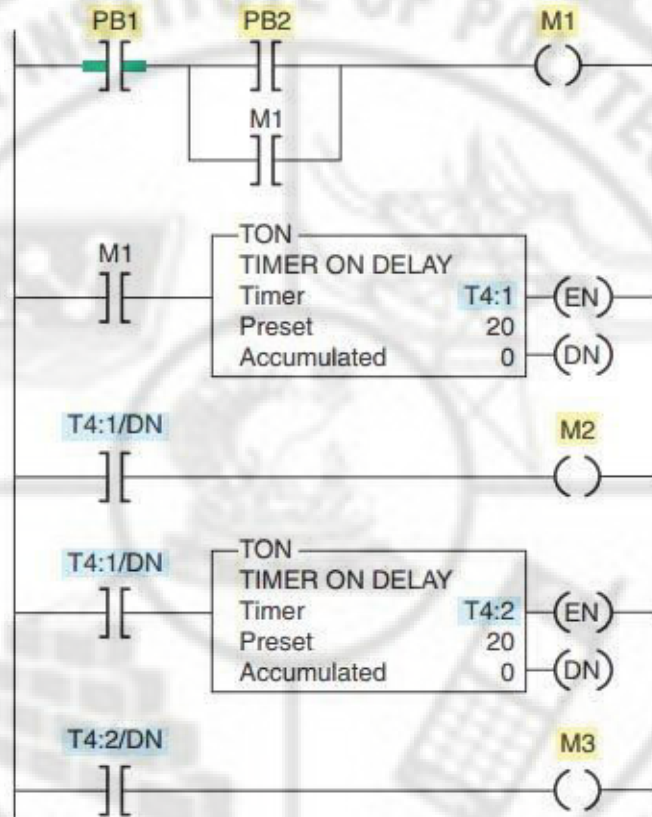

The operation of the circuit can be summarized as follows:

- i) Motor starter coil M1 is energized when the momentary start pushbutton PB2 is actuated.
- ii) As a result, motor 1 starts, contact M1 closes to seal in PB2, and timer coil T4:1 is energized to begin the first time-delay period.
- iii) After the preset time period of 20 s, T4:1/DN contact closes to energize motor starter coil M2.
- iv) As a result, motor 2 starts and timer coil T4:2 is energized to begin the second time-delay period.
- v) After the preset time period of 20 s, T4:2/DN contact closes to energize motor starter coil M3, and so motor 3 starts.
- vi) Hence actual time delay to start Motor 3 = Time delay of T4:1 + Time delay of T4:2

Counter Instruction

- ✓ Counter instructions are output instructions.
- ✓ Counter instructions are programming instructions that replace the need for electromechanical counter.

- ✓ A counter instruction has two values associated with it:
 - ✓ • the preset value
 - ✓ • the accumulated value
- ✓ The preset value specifies the target number of counts, while the accumulated value indicates the actual number of counts that have already occurred.
- ✓ In a counter, the preset and accumulated values always increase or decrease in increments of one.
- ✓ Each Allen-Bradley PLC 5 and SLC 500 counter instruction occupies three memory word locations in the C5 counter datafile.
- ✓ These three data words are the control word, preset word and accumulated word.
- ✓ **Control word:**
 - ✓ **Count-down Enable bit:** The count down enable bit is used with the count down counter and is true whenever the count down instruction is true.
 - ✓ **Done bit (DN) :** The done bit is true whenever the accumulated value is equal to or greater than the preset value of the counter.
 - ✓ **Overflow bit (OV) :** The overflow bit is true whenever the counter counts past its maximum value which is 32,767.
 - ✓ **Underflow bit (UV) :** The underflow bit will go true when the counter counts below -32768.

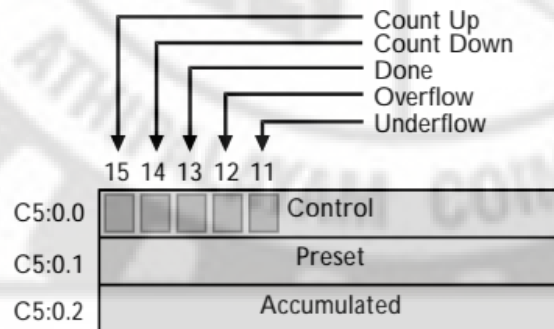

The data stored in each word of a counter's address

- ✓ **Preset Value:(PRE)**
 - The preset value specifies the value that the counter must count to before it changes the state of the done bit. The preset value is the set point of the counter and ranges from -32,768 to +32,768.
- ✓ **Accumulated value:(ACC)**
 - It is the current count based on the number of times the rung goes from false to true. It can also range from -32,768 to +32,768.

UP Counter

Up-counters perform a counting function when the associated input element transitions from an OFF to ON state. Up-counters begin at some preset value and increment upward. Up-counters are retentive and require an associated reset element to clear the counted values.

Counter Up Instruction: (CTU)

- ✓ A count up instruction is represented by the symbol shown in Figure below.
- ✓ The function of a count up instruction is to increase its accumulated value by one every time the block's input makes an OFF-to-ON transition.
- ✓ After a certain number of OFF-to-ON transitions have occurred, the count up instruction will energize its output.
- ✓ A count up block has two output coils:
 - a count up output coil (CU) : which indicates that the counter block is energized
 - a done output coil (DN), which indicates that the count is complete

Example:

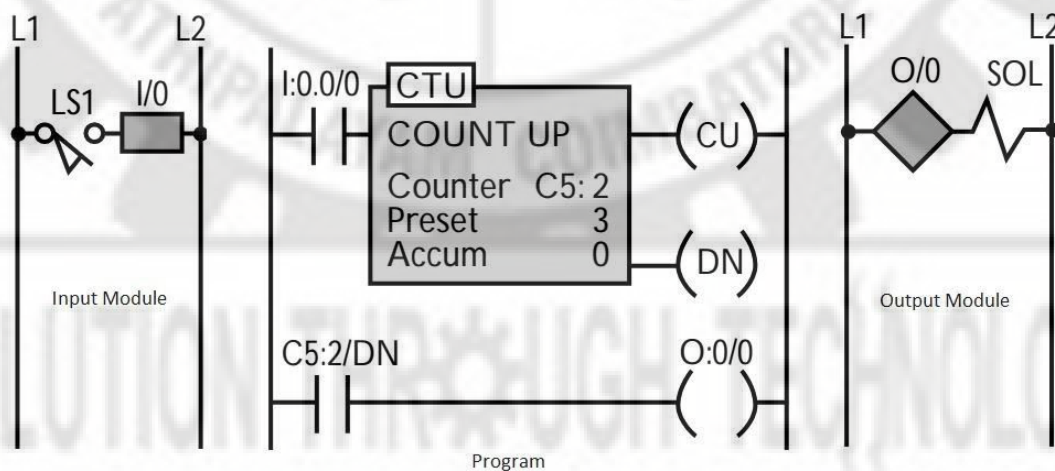

The solenoid (SOL) should turn on after the limit switch (LS1) has turned on three times. The circuit operates as follows:

- ✓ When the limit switch turns on for the first time, the count up output will be energized, and the accumulated value will increase to 1.
- ✓ When the limit switch turns off then on again, the accumulated value will increase to 2.
- ✓ When the switch makes its third OFF-to-ON transition, the accumulated value will increase to 3 and the done output will turn on because the accumulated value is equal to the preset value.

- ✓ When the done output turns on, the solenoid output in the second rung will be energized.
- ✓ In a counter circuit, the counter will continue to count even after the accumulated value has reached the preset value.
- ✓ The done output will remain on as long as the accumulated count is greater than or equal to the preset count.
- ✓ The only way to reset the accumulated value and turn off the done output is to use a reset instruction.

DownCounter:

Down-counters perform a counting function when the associated input element transitions from an OFF to ON state. Down-counters begin at some preset value and decrement downward. Down-counters are retentive and require an associated reset element to clear the counted values.

Counter Down Instruction: (CTD)

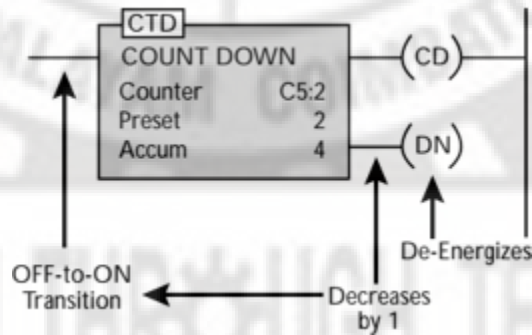

- ✓ A count down instruction decreases its accumulated value by one every time the block's input makes an OFF-to-ON transition.
- ✓ When the accumulated value becomes less than the preset value, the count down instruction de-energizes its output.
- ✓ When the counter's accumulated value is greater than or equal to its preset value, the counter's output will be on.
- ✓ A count down instruction also has two outputs:
 - a count down output : which indicates that the counter is energized
 - a done output : which signals that the target count value has been reached.

Example:

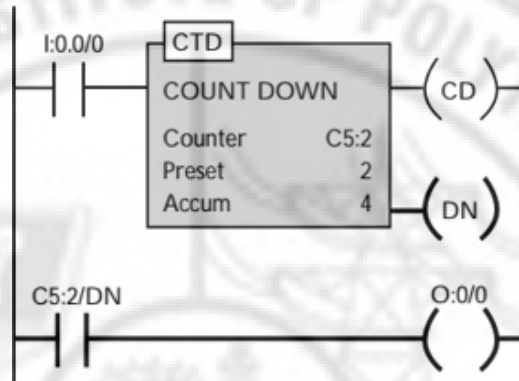

- ✓ In this circuit, the count down block's done output will already be on because the accumulated value is greater than the preset value.
- ✓ When the block's input I0.0/0 is turns from OFF to ON, the accumulated value will decrease to 3.
- ✓ When the block's input makes this OFF-to-ON transition again, the accumulated value will decrease to 2.
- ✓ When the input makes one more OFF-to-ON transition, the accumulated value will drop to less than the preset value and the done output will turn off, deenergizing the done output C5:2/DN and output O:0/0.
- ✓ The CTD instruction requires the RES instruction to reset its accumulated value and status bits.

UP/DOWN Counter:

- ✓ In the up/down counter shown in Figure below, both counters share the same address and the same preset and accumulated values.
- ✓ As a result, the up counter increases the accumulated value every time a certain event occurs, while the down counter decreases the same accumulated value if another event occurs.

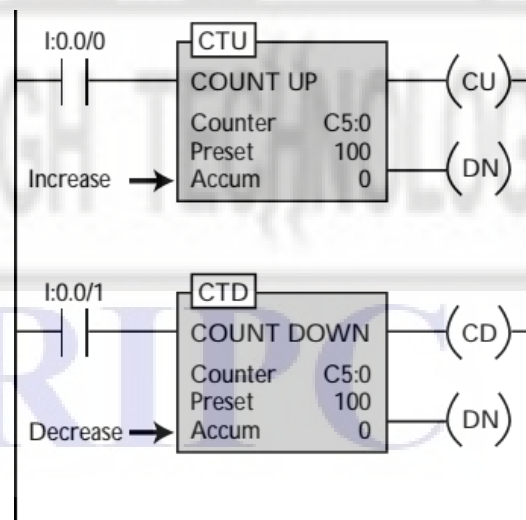

Cascading counters:

Depending on the applications, it may be necessary to count events that exceed the maximum number allowable per counter instruction. One way of accomplishing this count is by interconnecting or cascading two counters.

- ✓ A counter instruction's accumulated value has a range from -32,768 to +32,767.
- ✓ Once a counter reaches a count of +32,767, it cannot go any higher. Therefore, it wraps the accumulated count back around to -32,768 and starts counting up again.
- ✓ To count past the +32,767 count value, you must cascade two counters, making sure that they self-reset in each scan.
- ✓ When two counters are cascaded, they are programmed so that one counter provides the input to the other counter (see Ladder below).
- ✓ Ladder shows below has two cascaded counters that implement a count to 100,000. These cascaded counters have addresses C5:10 and C5:11.

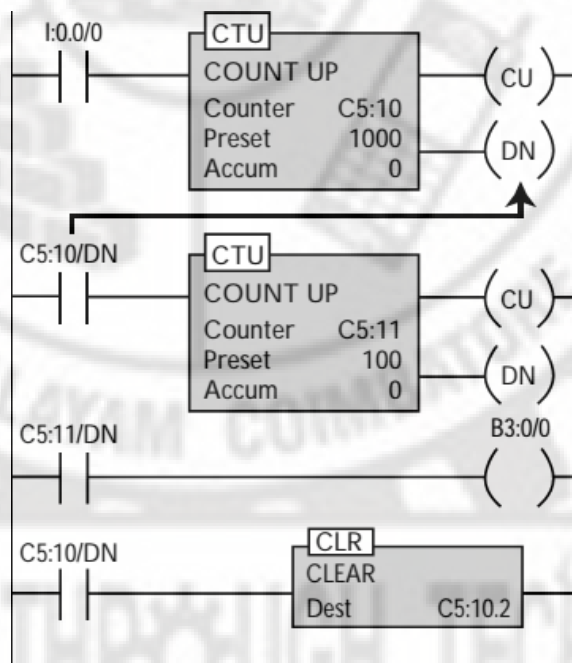

Ladder Diagram for DOLstarter:

764 - SRIPC

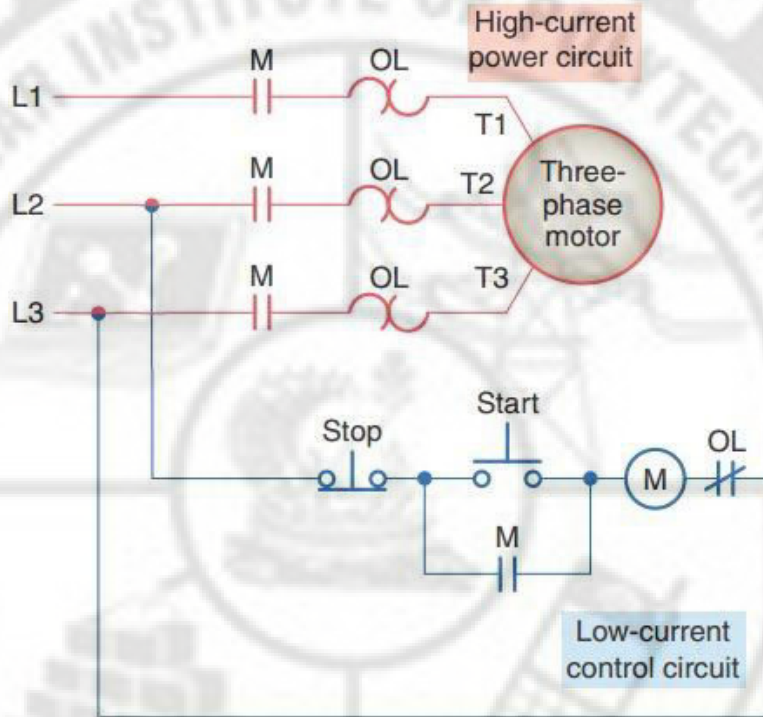

Figure : Hard Wire Circuit

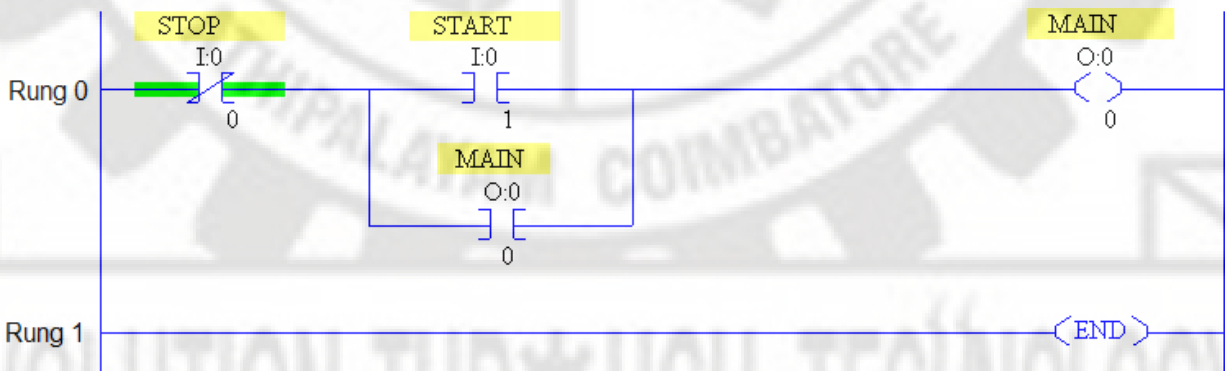

Figure: PLC Ladder Diagram for DOL Starter (Allen Bradley PLC)

Sequence of operation:

i)	Rung 0:	When the Start push button is pressed, the NO instruction I:0/1 is set to HIGH. The Rung 0 is TRUE and allows to energise Main coil which is connected to output instruction O:0/0. The NO contact of output instruction O:0/0 is set to high and provides sealing effect. The motor is started with full line voltage and continues to run.
ii)	Rung 1:	When the stop push button is pressed, the NC instruction I:0/0 is set to LOW. Now Rung 0 is FALSE and deenergise Main coil and stop the motor.

Automatic Star Delta Starter:

Sequence of operation:

i)	Rung 0:	When the Start push button is pressed, the NO instruction I:0/1 is set to HIGH. The Rung 0 is TRUE and allows to energise Star coil which is connected to output instruction O:0/0. The NO contact of output instruction O:0/0 is set to high and provides sealing effect.
ii)	Rung 1:	The NO contact of star coil output instruction O:0/0 is set to high and allows to energise Main coil which is connected to output instruction O:0/1 and ON delay Timer instruction T4:0. Now the motor is started with star connection.
iii)	Rung 2:	Timer T4:0 will close its NO contact T4:0/DN after the preset time delay. Now the motor is disconnected from star connection. (Neither star nor delta).
iv)	Rung 3:	After the preset time delay, T4:0/DN is closed and allows to energise ON delay Timer T4:1.
v)	Rung 4:	After the preset time delay of T4:1, it closes its NO contact T4:1/DN and allows to energise Delta coil which is connected to output instruction O:0/2. Timer T4:1 is used to provide pause time between star to delta transition. Now the Motor continues to run with delta connection.

764 - SRIPC

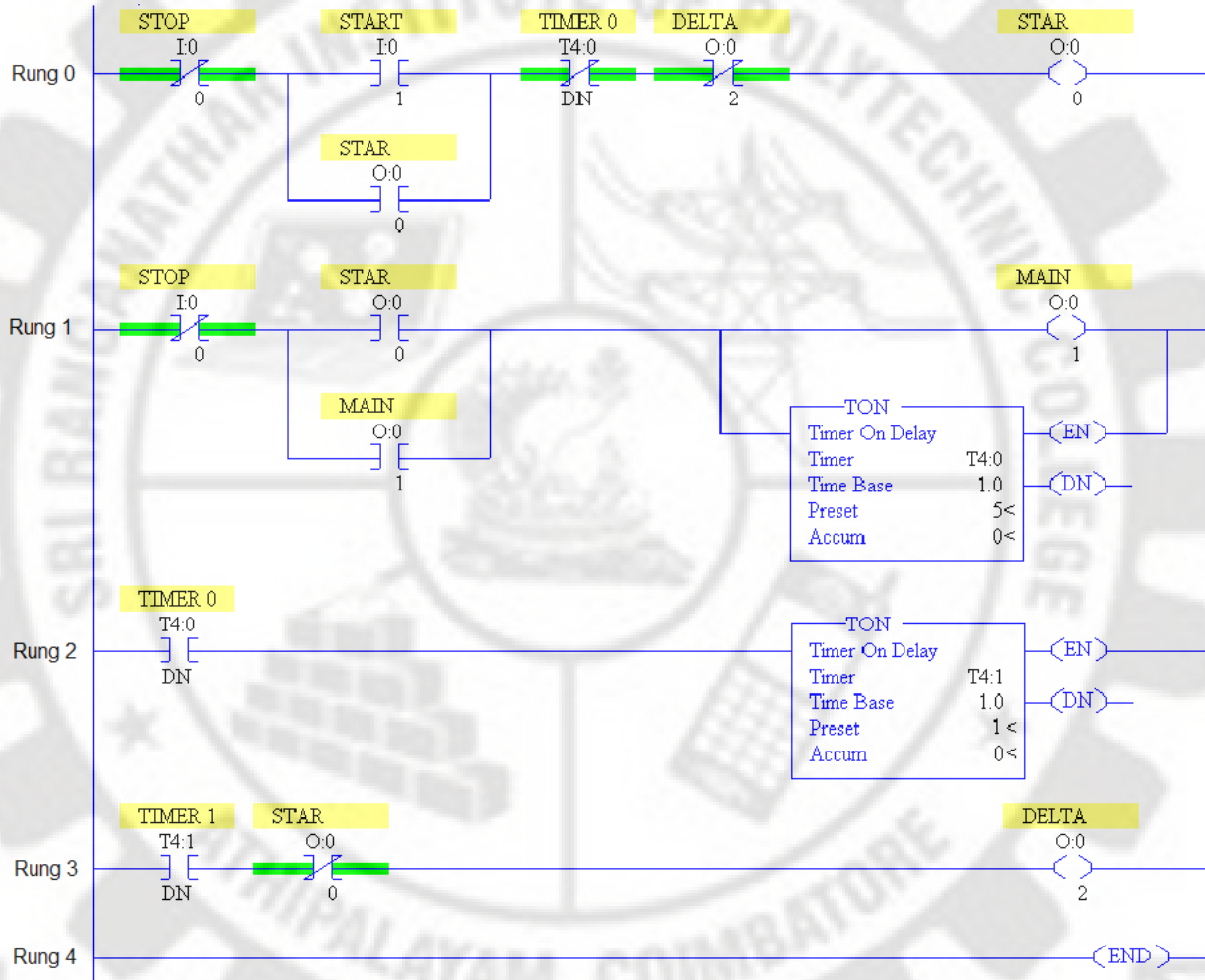
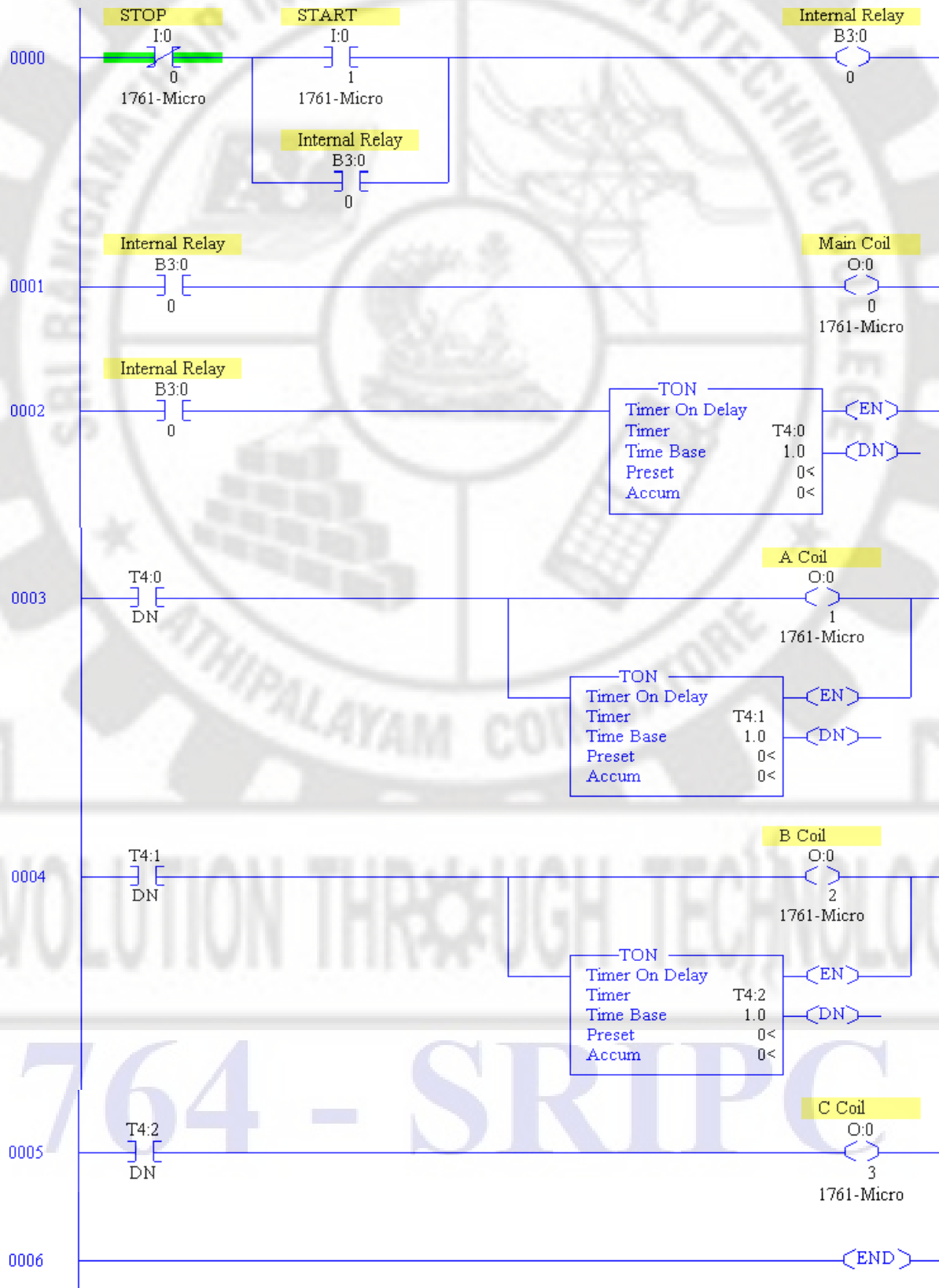

Figure : PLC Ladder Diagram for Star-Delta Starter (Allen Bradley PLC)

vi)	Rung 5:	When the stop push button is pressed, the NC instruction I:0/0 is set to LOW. Now Rung 0 is FALSE and deenergise star coil, main coil and delta coils.
-----	---------	--

764 - SRIPC

Rotor Resistance Starter



Sequence of operation:

i)	Rung 0:	When the Start push button is pressed, the NO instruction I:0/1 is set to HIGH. The Rung 0 is TRUE and allows to set internal relay or memory B3:0/0 to HIGH. The NO contact of internal memory B3:0/0 set to high in rung 0 provides sealing effect.
ii)	Rung 1:	The NO contact of internal memory B3:0/0 set to high in rung 1 and allows to energise main coil which is connected to the output instruction O:0/0. Now the slip ring induction motor is started with external rotor resistance.
iii)	Rung 2:	The NO contact of internal memory B3:0/0 set to high in rung 2 and allows to energise TON Timer coil T4:0.
iv)	Rung 3:	After the preset time delay, T4:0/DN is closed and cut down 1/3 rd resistance in the rotor circuit by energising 'A' Coil O:0/0. Now the motor continues to run with 2/3 rd of external rotor resistance. Closing of T4:0/DN allows to energise ON delay Timer T4:1.
v)	Rung 4:	After the preset time delay, T4:1/DN is closed and cut down 2/3 rd resistance in the rotor circuit by energising 'B' Coil O:0/1. Now the motor continues to run with 1/3 rd of external rotor resistance. Closing of T4:1/DN allows to energise ON delay Timer T4:2. After the preset time delay, T4:2/DN is closed and cut down full resistance in the rotor circuit by energising 'C' Coil O:0/2. Now the motor continues to run without external rotor resistance. Now the rotor terminals will be short circuited.
vi)	Rung 5:	When the stop push button is pressed, the NC instruction I:0/0 is set to LOW. Now Rung 0 is FALSE and deenergise remaining coils in remaining rungs.

EB to Generator Changeover:

764 - SRIPC

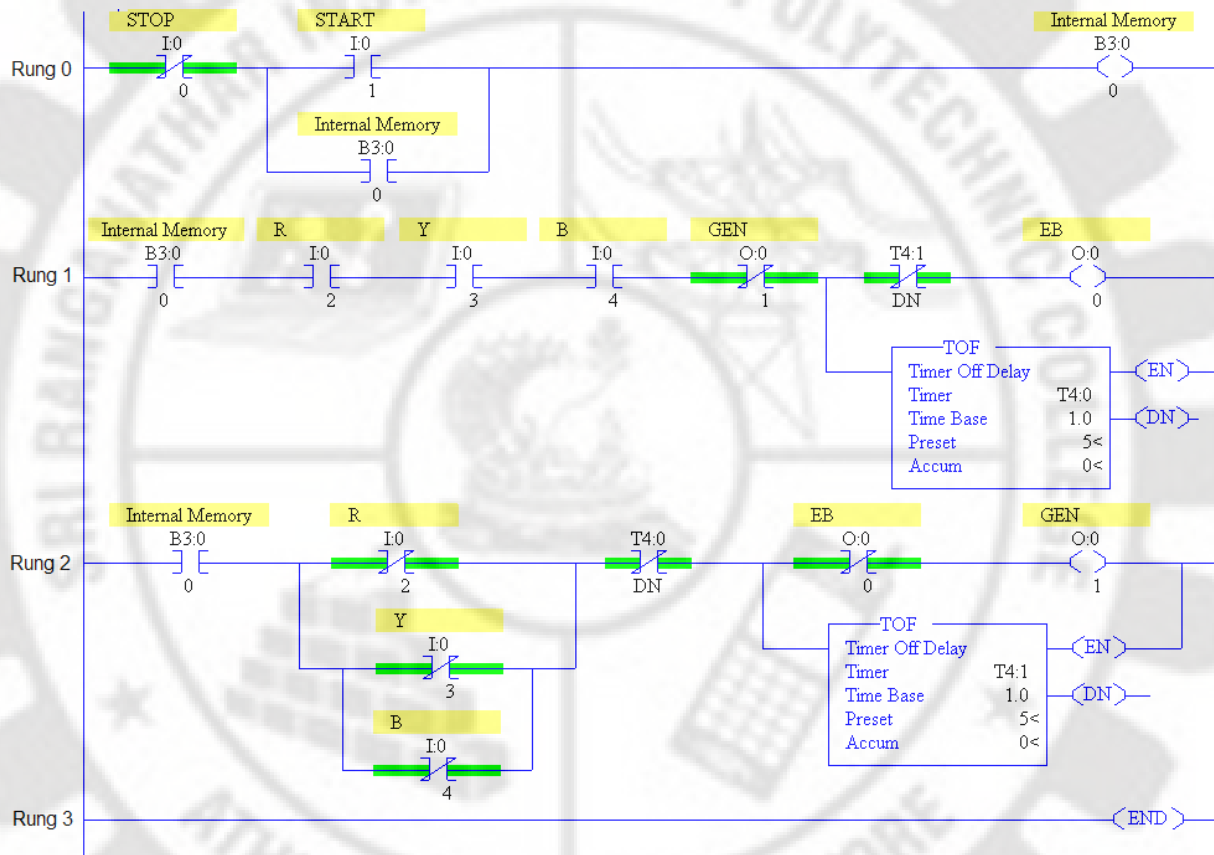

Sequence of operation:

i)	Rung 0:	When the Start push button is pressed, the NO instruction I:0/1 is set to HIGH. The Rung 0 is TRUE and allows to set internal memory B3:0/0 to HIGH. The NO contact internal memory B3:0/0 to high in rung 0, rung 1 and 2. NO contact B3:0/0 in rung provides sealing effect.
ii)	Rung 1:	<p>i) Three sensors can be used to sense the availability of phases. If 'R', 'Y' and 'B' phases are available, the corresponding NO contact I:0/2, I:0/3 and I:0/4 will set to high. Now EB coil which is connected with output instruction O:0/0 and OFF delay Timer instruction T4:0 are energized. Now EB supply lines will be connected to the load circuit.</p> <p>ii) If any one of the three phases are not-available, the corresponding NO contact will set to LOW. Now EB coil which is connected with output instruction O:0/0 and OFF delay Timer instruction T4:0 are de-energized. Now EB supply lines will be disconnected to the load circuit. Timer T4:0</p>

		will operate its NC contact T4:0/DN in rung 2 after preset time delay.
iii)	Rung 2:	<p>i) Because of presence of 'R', 'Y' and 'B' phases, the corresponding NC contact I:0/2, I:0/3 and I:0/4 will set to low. Without time delay Timer T4:0 will open its NC contact T4:0/DN immediately and the EB interlock contact O:0/0 also opened to make rung 2 as FALSE. Now GEN coil which is connected with output instruction O:0/1 and OFF delay Timer T4:1 are set to LOW.</p> <p>ii) If any one of the three phases are not-available, the corresponding NC contact will set to HIGH. EB interlock contact O:0/0 is closed and after preset time delay NC contact T4:0/DN will come to closed condition to make rung 1 as TRUE. Now GEN coil which is connected with output instruction O:0/1 and OFF delay Timer T4:1 are set to HIGH. Without time delay Timer T4:1 will open its NC contact T4:1/DN immediately and the GEN interlock contact O:0/1 also opened to make rung 1 as FALSE.</p>
iv)	Rung 0:	When the stop push button is pressed, the NC instruction I:0/0 is set to LOW. Now Rung 0 is FALSE and deenergiseremaining coils in remaining rungs.

764 - SRIPC

UNIT – V PLC ROGRAMMING

MODEL QUESTIONS

Two Mark Questions:

1. Name the different types of PLC programming languages.
2. Expand the term FBD and STL.
3. Expand the term SFC and ST.
4. What is ladder diagram?
5. Give any 2 relay type instructions.
6. Explain EXAMINE IF CLOSED instruction and assign its address.
7. Explain EXAMINE IF OPEN instruction and assign its address.
8. Draw the symbol of LATCH instruction and assign the address.
9. Draw the symbol of UNLATCH instruction and assign the address.
10. State the different types of timer instruction.
11. What is a TON instruction?
12. What is a TOF instruction?
13. State the different types of timer instruction.
14. What is a CTU instruction?
15. What is a CTD instruction?
16. What is preset in timer instruction?
17. What is accumulator in timer instruction?
18. What is preset in counter instruction?
19. What is accumulator in counter instruction?
20. What is the need of cascaded timer instruction?
21. What is the need of cascaded counter instruction?

Three Mark Questions:

1. Write short notes on ladder diagram.
2. Draw the schematic diagram of scanning of ladder diagram.
3. Write short notes on FBD.
4. Write short notes on STL.
5. Write short note on XIC instruction.
6. Write short note on XIO instruction.
7. Write short note on OTE instruction.
8. Write short note on OTL instruction.
9. Write short note on OTU instruction.
10. Write short note on OSR instruction.
11. Why do we need timer instructions?
12. Explain various parameters associated with timer instruction.

13. Develop simple ladder logic using TON instruction.
14. Develop simple ladder logic using TOF instruction.
15. Develop simple ladder logic using CTU instruction.
16. Develop simple ladder logic using CTD instruction.
17. What is a RTO instruction?
18. Why do we need counter instructions?
19. Explain various parameters associated with counter instruction.

Ten Mark Questions:

1. Briefly discuss about different types of PLC programming languages.
2. With neat symbol explain about different types of relay type instructions.
3. What is a TON instruction? Explain its working with the help of suitable ladder diagram and timing diagram.
4. What is a TOF instruction? Explain its working with the help of suitable ladder diagram and timing diagram.
5. Explain the operation of cascaded timers with suitable ladder diagram.
6. What is a CTU instruction? Explain its working with the help of suitable ladder diagram and timing diagram.
7. What is a CTD instruction? Explain its working with the help of suitable ladder diagram and timing diagram.
8. Make UP-DOWN counter using CTU and CTD instructions and explain its working.
9. Explain the operation of cascaded counters with suitable ladder diagram.
10. Develop ladder logic for DOL starter and explain the sequence of operation.
11. Develop ladder logic for star delta starter and explain the sequence of operation.
12. Develop ladder logic for rotor resistance starter and explain the sequence of operation.
13. Develop ladder logic for EB to Generator changeover and explain the sequence of operation.

764 - SRIPC

CONTROL OF ELECTRICAL MACHINES

MODEL QUESTION PAPER

Duration:3Hrs

Max.Marks:75

- [N.B: (1) Answer any FIVE questions in each PART – A and PART - B.
Q.No.8 in PART - A and Q.No.16 in PART - B are compulsory.
(2) Answer division (a) or division (b) of each question in PART - C.
(3) Each question carries 2 marks in PART-A, 3 marks in PART-B and 10 marks in PART-C]

PART – A

1. Draw the symbol of push button and selector switch.
2. Define D.C. series current relay.
3. What will be the rotor frequency at the time of starting slip ring induction motor?
4. What is need of time delay relay in skip hoist control?
5. What are the advantages of fixed automation?
6. What is the use of output imager table?
7. Give any 2 relay type instructions.
8. Expand the term FBD and STL.

PART – B

9. Write short note on proximity switch.
10. Draw the control circuit of simple ON/OFF motor control.
11. Write a note on closed circuit transition in auto transformer starter.
12. List the industrial applications of Electric Oven.
13. List the types and example of combination problem as applied to machine control.
14. Compare PLC circuit versus hardwired circuits. (any 3)
15. List the name of any six market available PLC.
16. What is a RTO instructions?

PART – C

17. (A) Explain the construction and working of drum switch with a neat sketch.

(or)

(B) Explain the construction and working principle of magnetic dashpot oil filled relay.

18. (A) Explain the control circuit and power circuit of autotransformer starter with neat sketch.

(or)

(B) Explain the control and power circuit of automatic rotor resistance starter for three phase slip ring induction motor with neat sketch

19. (A) Explain the schematic arrangement and control circuit of automatic control of water pump.

(or)

(B) Briefly discuss about general procedure for trouble shooting in control circuit.

20. (A) Draw and explain the block diagram of PLC.

(or)

(B) With neat sketch explain the operation of D.C discrete output module.

21. (A) What is a TON instruction? Explain its working with the help of suitable ladder diagram and timing diagram.

(or)

(B) Develop ladder logic for EB to Generator changeover and explain the sequence of operation.